

Vehicle Electrification System Standards

IV. High Voltage Battery Pack System

IV.c HV Battery Pack System (RESS)

OEM Acronyms:

RESS

Description:

The Battery Pack (RESS) system contains modules or cells, and all of the necessary sensor and control systems that, will permit electrochemical energy to be stored and utilized by the electric propulsion system.

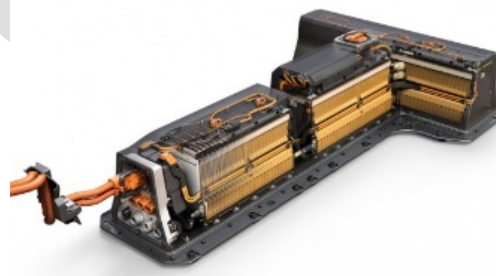
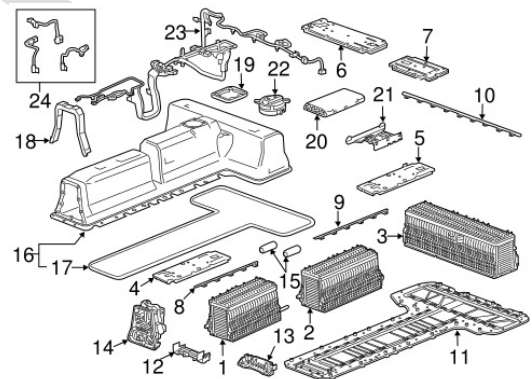
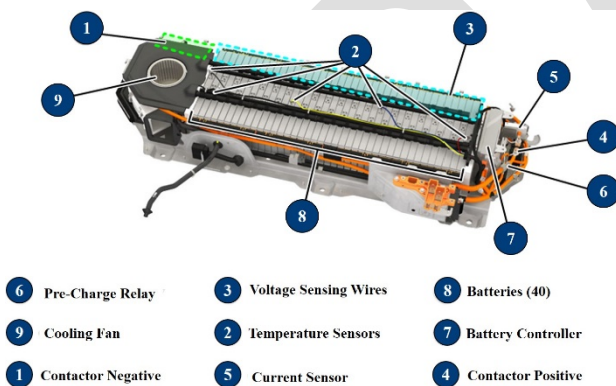

Outcome (Goal):

Students shall be able to identify and define components within the High Voltage Battery Pack.







Objective:



When provided a physical or graphic diagram of a High Voltage Battery Pack, students will be able to identify each major component and define its function.





Task:

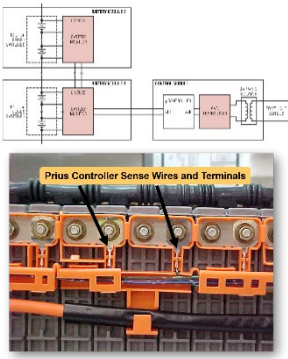

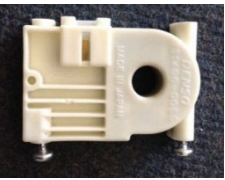
Students will complete a worksheet to identify and label High Voltage Battery Pack components in the provided pictures or diagrams, using OEM vehicle service and component supplier information, while using proper technical terminology, acronyms, and definitions.



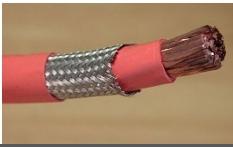

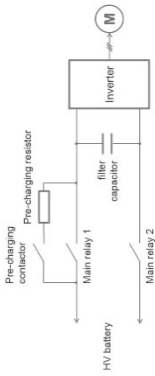

	Name	Definition
	Battery Carrier	The framework enclosure that houses all of the battery pack internal components
	Battery Cell and Module Formats	
 	NiMH	
	Cylindrical	A battery that is manufactured in the shape of a cylinder
	Prismatic	A battery that is manufactured in the shape of a rectangle
  	Lithium Ion	
	Cylindrical	A battery that is manufactured in the shape of a cylinder
	Pouch	A battery that is manufactured in the shape of a flat rectangle
	Prismatic	A battery that is manufactured in the shape of a rectangle
	Battery Control Module (BCM)	The electronic controller that controls the operation of a high voltage battery pack

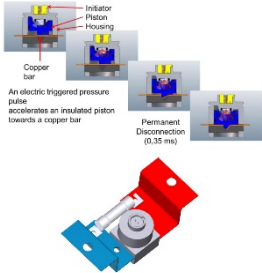

	<p>Voltage Sensing System</p>	<p>The hardware sub-system, comprised of circuits within the BCM and a sensing delivery system (wiring harness or wireless) that, provides battery module/cell terminal voltage information to the BCM software/firmware</p>
	<p>Temperature Sensing</p>	<p>The hardware sub-system, comprised of circuits within the BCM and a sensing delivery system (wiring harness or wireless) that, provides battery module/cell surface temperature information to the BCM software/firmware</p>
	<p>Air</p>	<p>NTC or PTC sensor that changes its resistance with a change in incoming or ambient battery pack temperature</p>
	<p>Module & Cell</p>	<p>NTC or PTC sensor that changes its resistance with a change in battery module/cell surface temperature</p>
	<p>Current Sensor</p>	<p>A Hall Effect technology sensor that is used for sensing the magnitude of electrical current entering or exiting the battery pack and report this information to the BCM in the form of a voltage. The information from this sensor will be used to calculate SOC%, SOH, and correlate data between the BCM and Power Inverter Module.</p>

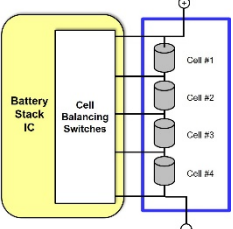
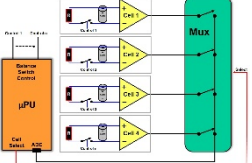

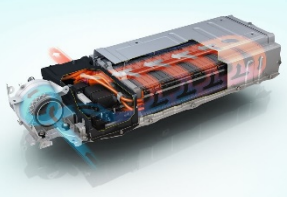
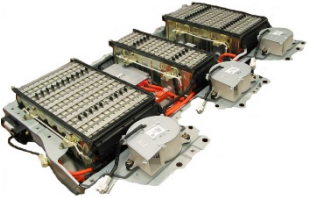

	Module & Cell Connection System	
	Fasteners	Nuts, Bolts, and Washers used to connect Bus Bars to battery modules or cells
	Bus Bars	Copper or Copper Alloy component that is used to physically connect modules/cells in a series and parallel configuration that will comprise the total voltage of a battery pack
	Welded	Laser, Pulse, Resistance, or Ultrasonic welding technology that connects modules/cells in a series and parallel configuration that will comprise the total voltage of a battery pack
	Cable and Wire	
	Unshielded Wire/Cable	Wire or cable that does not contain an aluminum or copper shielding system to reduce EMI or EMC
	Shielded Wire/Cable	Wire or cable that contains an aluminum or copper shielding system to reduce EMI emissions and enhance EMC
	Contactor(s) (Cont. or C)	Contactors are used for high voltage switching purposes whereas relays are used for low voltage switching. Contactors and Relays perform the same task of switching a circuit. An energy control system can utilize one or more contactors. The battery pack are located within the battery pack but, the HV charger contactors can be located internal or external of the battery pack.

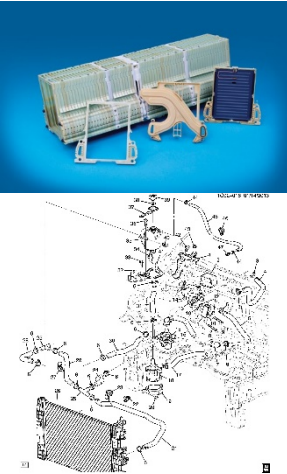
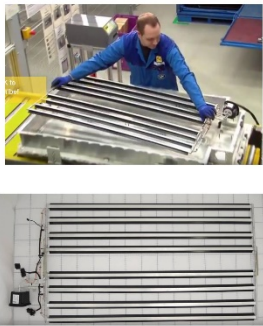
	<p>Pre-Charge Circuit (PC)</p>	<p>An electrical circuit, located within the battery pack, that is utilized on each vehicle power ON cycle to reduce inrush currents to ensure battery pack and power systems components are not damaged by the inrush currents. In systems with low impedance components that cause high peak current capability (i.e. with capacitors and low impedance circuitry), the fuse can be melted and vaporized so fast that an explosion occurs. The Pre-Charge circuit is typically comprised of a dedicated Contactor (that is only used during the Pre-Charge cycle) and a Power Resistor to reduce inrush current.</p>
	<p>Bus Bars</p>	<p>Copper or Copper Alloy component that is used to physically connect modules/cells in a series and parallel configuration that will comprise the total voltage of a battery pack</p>
	<p>HV Fuse</p>	<p>A fuse is a circuit element located internal or external of the battery pack enclosure designed to melt (due to heat generated by electrical current) when the current exceeds the time constant and current rating of the fuse, thereby opening the circuit. Systems with high peak current capability (i.e. with capacitors and low impedance circuitry), the fuse can be melted and vaporized so fast that an explosion occurs.</p>
	<p>Traditional</p>	<p>Fuse elements of fast acting fuses and HV fuses are primarily made of silver (Ag). Silver plated copper is also commonly used. As a rule, fuse elements of time delay fuses contain low melting point materials, e.g. tin (Sn) or zinc (Zn) and alloys thereof.</p>

 <p>Indicator Piston Housing Copper bar An electric triggered pressure pulse accelerates an insulated piston towards a copper bar Permanent Disconnection (0.35 ms)</p>	<p>Pyro</p>	<p>A type of fuse for high voltage that use explosive rather than melting metal bar. Under high voltage, an arc might form inside a normal metal fuse defeating the purpose of fuses. Pyrotechnic fuse prevents the arcing by disconnecting contacts quicker.</p>
	<p>Battery Module/Cell Balancing Systems</p>	<p>Electronic systems located within the battery pack controller that electrically or wirelessly connects the controller to individual battery cells or cell groups to ensure that the voltage tolerances are maintained by adding or subtracting energy from the battery cells during a balancing process.</p>
	<p>Active Balancing</p>	<p>A balancing process by which energy is shuttled from cells with a higher terminal voltage to cells with a lower terminal voltage to ensure a tight voltage tolerance between all battery cells or cell groups. This process ensures that there is minimal energy loss because no energy is dissipated to achieve cell or cell group balancing.</p>
	<p>Passive Balancing</p>	<p>A balancing process by which energy is discharged from the highest battery cell or cell group so the terminal voltages of the highest cell are lowered to match the voltage of the lowest cell or cell group in the battery pack.</p>

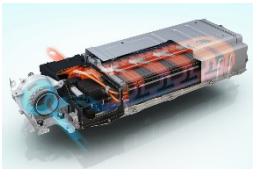
	Battery Pack Cooling System	A thermal system that ensures that the temperature of the battery pack internal components are maintained within the confines of a specific internal battery pack temperature.
	Ambient	A battery pack cooling strategy that does not utilize forced air or ancillary cooling system to maintain internal battery pack temperature within a specified range.
 	Forced Air	A battery pack cooling strategy that utilizes forced air to cool the battery pack with ambient air or air from an ancillary cooling system to maintain internal battery pack temperature within a specified range.

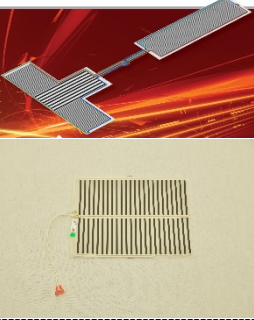
	<p>Liquid</p>	<p>A battery pack cooling strategy that utilizes a pressurized liquid that is pumped into the battery pack to cool the cells directly or indirectly to maintain battery cell temperatures within a specified range.</p>
	<p>HVAC</p>	<p>A battery pack cooling strategy that utilizes conditioned air from the vehicle A/C system that is pumped into the battery pack to directly or indirectly to maintain battery cell temperatures within a specified range.</p>
	<p>Submersed</p>	<p>A battery pack cooling strategy that completely submerges the battery pack cells or cell groups in a non-conductive and non-corrosive liquid for direct cooling to maintain battery cell temperatures within a specified range.</p>

Battery Pack Heating System	
	<p>Forced Air A battery pack heating strategy that utilizes forced air to heat the battery pack with ambient air or air from an ancillary heating system to maintain internal battery pack temperature within a specified range.</p>
	<p>Liquid A battery pack heating strategy that utilizes a pressurized liquid that is pumped into the battery pack to heat the cells directly or indirectly to maintain battery cell temperatures within a specified range.</p>
	<p>Electric Grid A battery pack heating strategy that utilizes an electrical grid to heat the battery cells or cell groups to maintain battery cell temperatures within a specified range.</p>
	<p>Submersed A battery pack heating strategy that will directly heat submerged battery pack cells or cell groups with a non-conductive and non-corrosive liquid to maintain battery cell or cell groups temperatures within a specified range.</p>

	Battery Module/Cell Failure Modes	Failure Modes that occur during the service life of a battery cell or cell group that is attributed to a specific format, design, heating/cooling system, geographic area, terrain, drive cycle, and chemistry formula
	Diagnostics & DTCs	Diagnostic Codes are a software or firmware-based coding system that assigns specific failure modes of the battery cells or cell groups to a specific failure mode electronic code.

To comment or offer suggestions on this standard, contact Ken Mays:

Ken Mays	NEVTEX
541-383-7753	kmays@cocc.edu

