

**2017 Summer Professional Development Course
Advanced Automotive Technology**

**Topic 2:
Cooperative Connected Vehicles**

**Instructor: Dr. Radoven Muicic
Wayne State University**

July 10 ~ 11, 2017

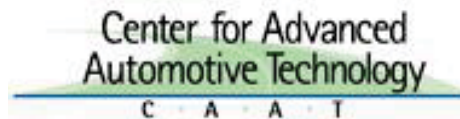

Overview

- Connected Vehicles
- DSRC Intro
- Cooperative Safety Applications: V2V, V2P, and V2I
- Vehicle Positioning
- Connected and Autonomous Vehicle
- DSRC Scalability
- DSRC Security, Privacy, Threats and Requirements

Connected Vehicles

Prepared by Radovan Miucic

Connected Vehicle Applications

- **Hard Safety Applications e.g.**
 - Emergency Electronic Brake Light (EEBL)
 - Intersection Movement Assist (IMA)
- **Soft Safety Applications**
 - Weather, road, traffic condition advisory
 - E.g. Icy Road ahead, construction, reduced visibility, pot holes, traffic jams
- **Mobility and Convenience**
 - **Mobility:** navigation, road guidance, traffic information, assistance and information services
 - **Convenience:** point of interest notification, e-mail, social networking, media download, app. Updates
 - E.g Ford's Sync (uses combination of user's smartphone with embedded display, sound and voice commands)

Copyright 2017 by Radovan Miuic

Connected Vehicle Applications

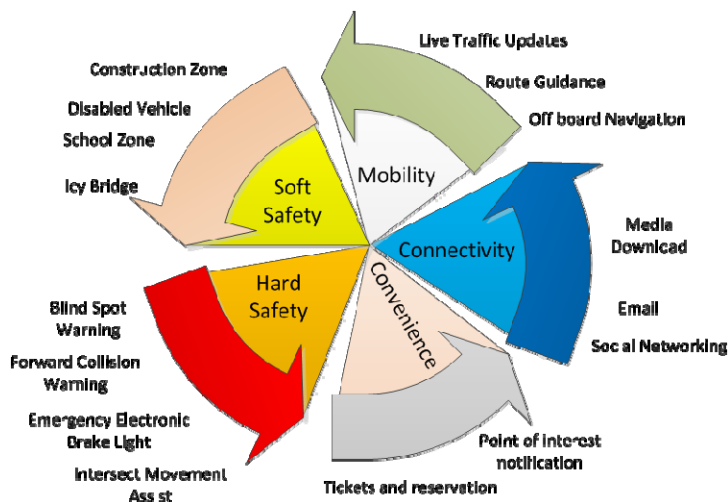

Copyright 2017 by Radovan Miuic

Uniqueness in Consumer Vehicle Networks

- Vehicles talk to each other and to the roadside infrastructure
- Vehicles may be only few seconds in communication range of each other or infrastructure
- Vehicles need to instantly communicate with each other to support hard safety application latency needs (100ms)
- Vehicle somehow need to trust other vehicles and infrastructure
- Designing networking and security system for ~250 million vehicles will be challenging

Copyright 2017 by Radovan Miucic

Vehicle Communication Modes

- Vehicle talk directly to other vehicles
- Vehicle talk to other vehicles via multi hop
- Vehicle talk to other vehicles through infrastructure
- Vehicle talk to application servers through infrastructure
- Infrastructure Broadcasts messages

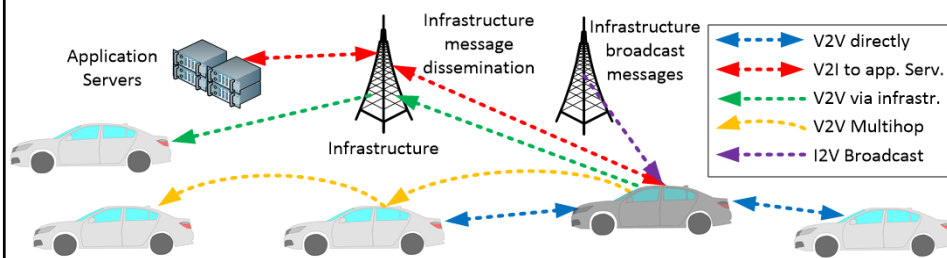

Copyright 2017 by Radovan Miucic

Comparison of wireless comm. technologies

	DSRC	Wi-Fi	Bluetooth	3G	4G LTE	SDARS
Range	Hundreds of meters	Hundreds of meters	Up to 100 m	Tens of kilometers	10s of meters up to 100 km	Countrywide
End-to-end message delay	10 ms	10 ms	10 ms	50 to 100's of ms	10's of ms	10-20 seconds
Connection/call setup time	Not needed	3-5 seconds	3-4 seconds	100's of ms to seconds	~50ms	Not applicable
V2V local broadcast	Yes	Yes	Impractical	With server	With server	No
V2V multihop messaging	Yes	Yes	Impractical	With server	With server	No
I2V local broadcasting	Yes	Yes	Impractical	Not offered by all network operators	Not offered by all network operators	Yes
V2I bidirectional	Yes	Yes	Impractical	Yes	Yes	No

SDARS = Satellite Digital Audio Radio Service

Copyright 2017 by Radovan Miuic

Backward Compatibility

- Wireless technology for a vehicle may get outdated before the end of the life
- New vehicles should benefit from new wireless technologies but they should be backward compatible and interoperable with existing vehicles
- Applications, design and standards have to take these requirements into consideration

Copyright 2017 by Radovan Miuic

WAYNE STATE UNIVERSITY

Example: Test Equipment Setup

Car setup **Motorcycle setup**

DSRC and GPS Antenna

Single DSRC Antenna under rear window.

OBU and DAS mounted in the vehicle trunk

Back Antenna Front Antenna

OBU and DAS Enclosure

Back DSRC and GPS Antennas

OBU and DAS

Front DSRC Ant.

SAE INTERNATIONAL

Copyright 2017 by Radovan Mijacic

WAYNE STATE UNIVERSITY

Example: Test Equipment Setup and DVI

DSRC and GPS antenna mounted on the roof

DVI: Alert Example

SAE INTERNATIONAL

10

Copyright 2017 by Radovan Mijacic

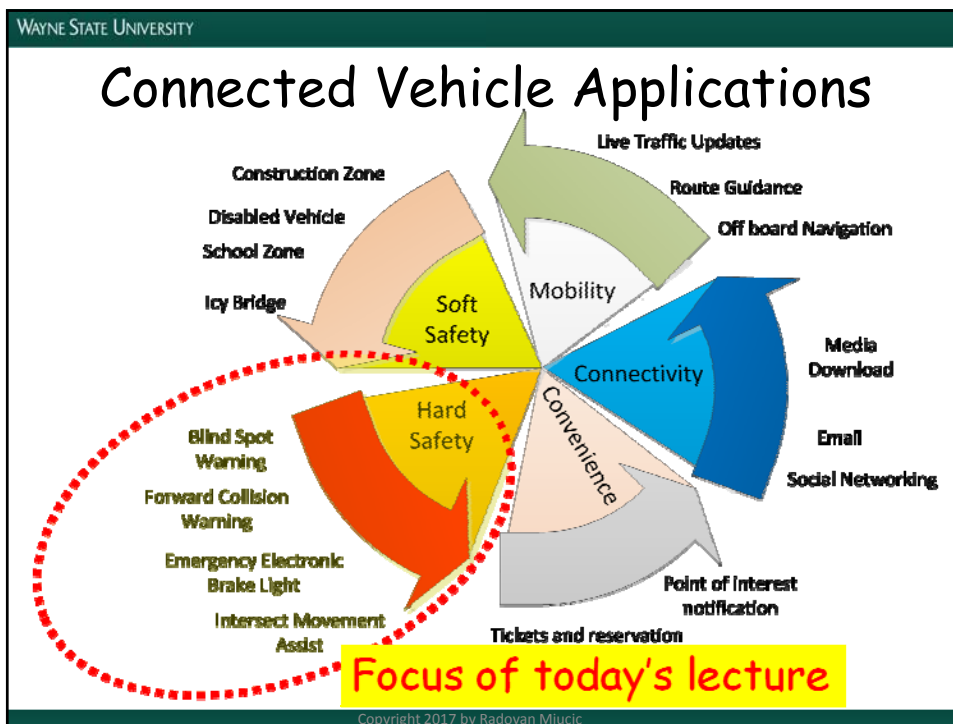

WAYNE STATE UNIVERSITY

Dedicated Short Range Communication (DSRC)

Prepared by Radovan Miucic

Copyright 2017 by Radovan Miucic

Licensed vs Unlicensed Spectrum

- **Licensed** radio bands
 - FCC allocates a frequency range
 - FCC usage (function) of the frequency band
 - FCC specify how the frequency range can be used or shared
 - a license must be obtained from a government agency
 - Examples: FM broadcast (87.5 to 108.0 MHz), Cellular phones (840 MHz), **DSRC(5.850-5.925 GHz)**

Licensed vs Unlicensed Spectrum

- **Unlicensed** radio bands
 - Regulations exist around these bands
 - Still need to use compliant devices
 - Do not need a license to use the spectrum (anyone can use)
 - Examples:
 - Industrial, Scientific, Medical (ISM): medical monitors and other devices (900-MHZ, 2.4-GHz, and 5-GHz bands)
 - Unlicensed National Information Infrastructure (U-NII): WLAN access points and routers (5-GHz band)
 - Unlicensed Personal Communications Services (UPCS): cordless phones (1.9-GHz band)

DSRC Usage and Channels

- Public safety apps through
 - Vehicle to Vehicle V2V
 - Vehicle to Infrastructure V2I
- High Availability Low Latency (HALL)
High Power Long Range (HPLR)

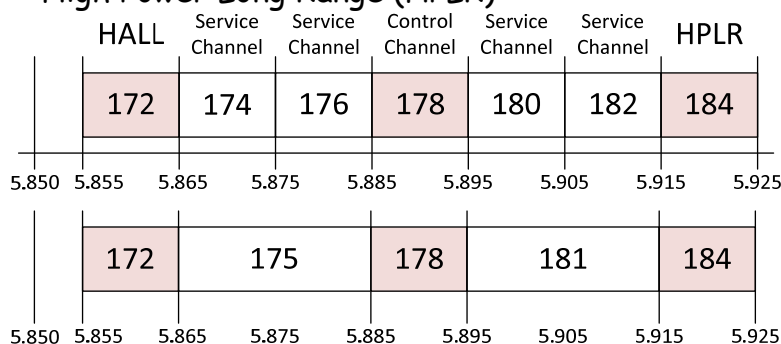

Copyright 2017 by Radovan Mlucic

DSRC Usage and Channels cont.

- CH172 is dedicated for V2V
 - Accident avoidance and safety of life and property apps
- CH178 is control channel
- CH184 is for public safety
 - Also for safety of life and property apps
- CH174, CH176, CH180, and CH182
 - Safety and non safety apps
- Center frequency (in MHz) from Channel Number:

$$f(CN) = 5000 + 5CN$$

Copyright 2017 by Radovan Mlucic

DSRC Operations

- DSRC is restricted in usage and communication technology
- Usage of devices (even at low power) that do not strictly comply with DSRC standards is not allowed
- Operating in 5.9 GHz spectrum
 - Avoids crowded cellular networks
 - Dedicated spectrum avoids competition from other wireless stations
 - Low weather dependency
 - Able to meet range requirements imposed by most safety apps
 - However, operating in high frequencies imposes some limitations: waves are not able to penetrate as far as low frequency signals, solid objects such as walls tend to absorb waves at 5.9 easily, limiting range in urban environments.

Copyright 2017 by Radovan Mlucic

DSRC Intro



- Connected Vehicle The Future of Transportation Video
<https://youtu.be/Q8Cn47L8FRQ>
- Dedicated Short Range Communication (DSRC)
- Each Car will be broadcasting periodically (or frequently) awareness messages to the neighboring vehicles
- There is no need for infrastructure for broadcast
- Awareness message is called Basic Safety Message (BSM)
- Payload content (application layer) of the BSM is defined in SAE J2735 standard.
- Rest of the slides are derived from 2009 SAE J2735 standard with some explanation

Copyright 2017 by Radovan Mlucic

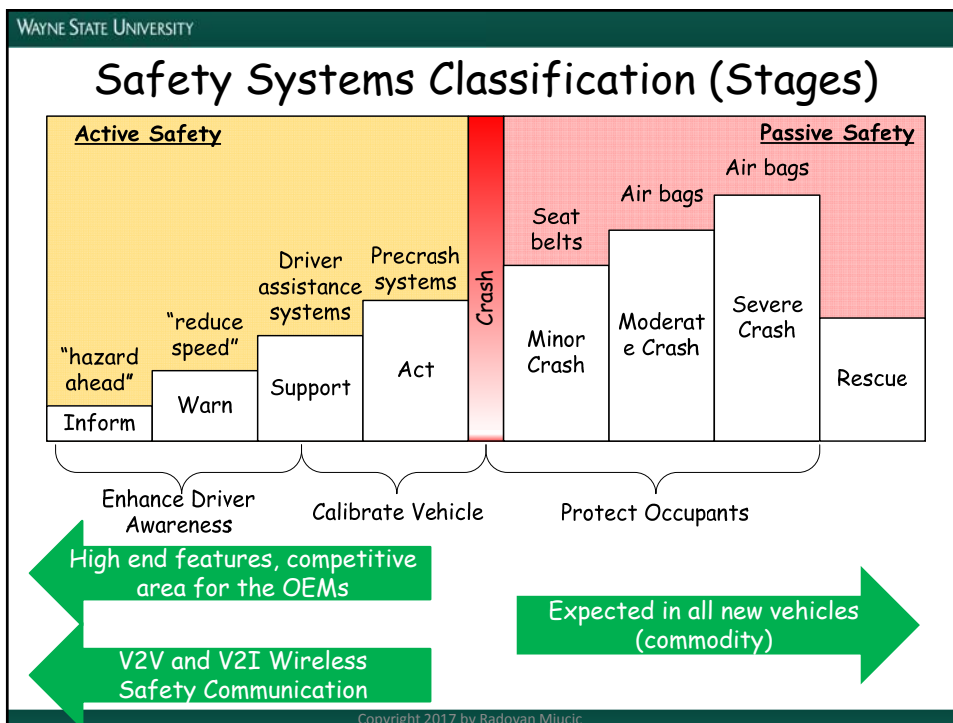
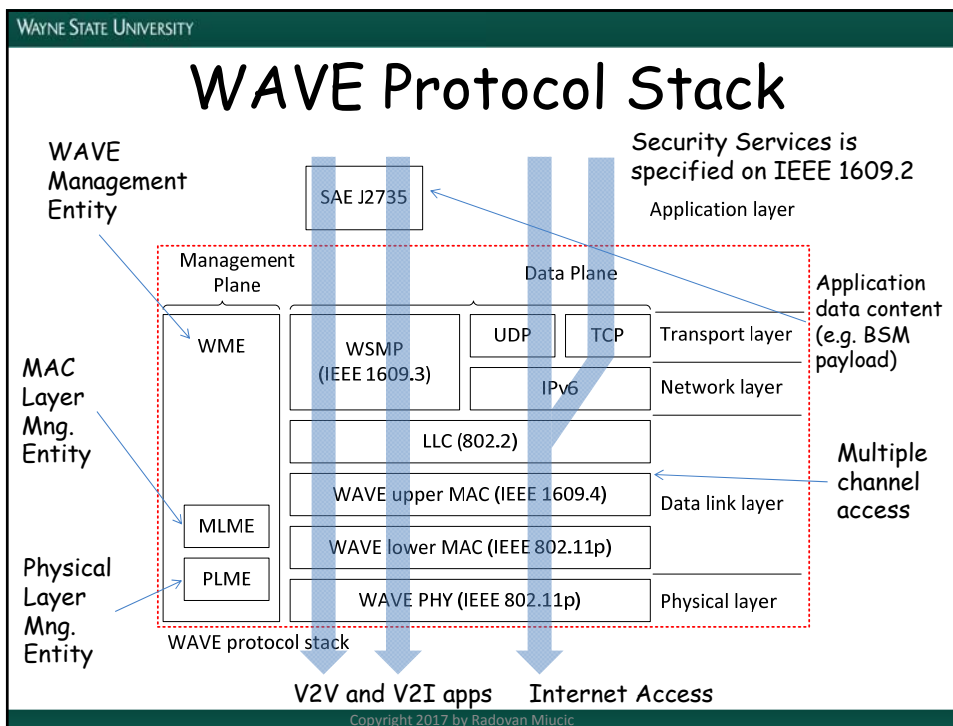

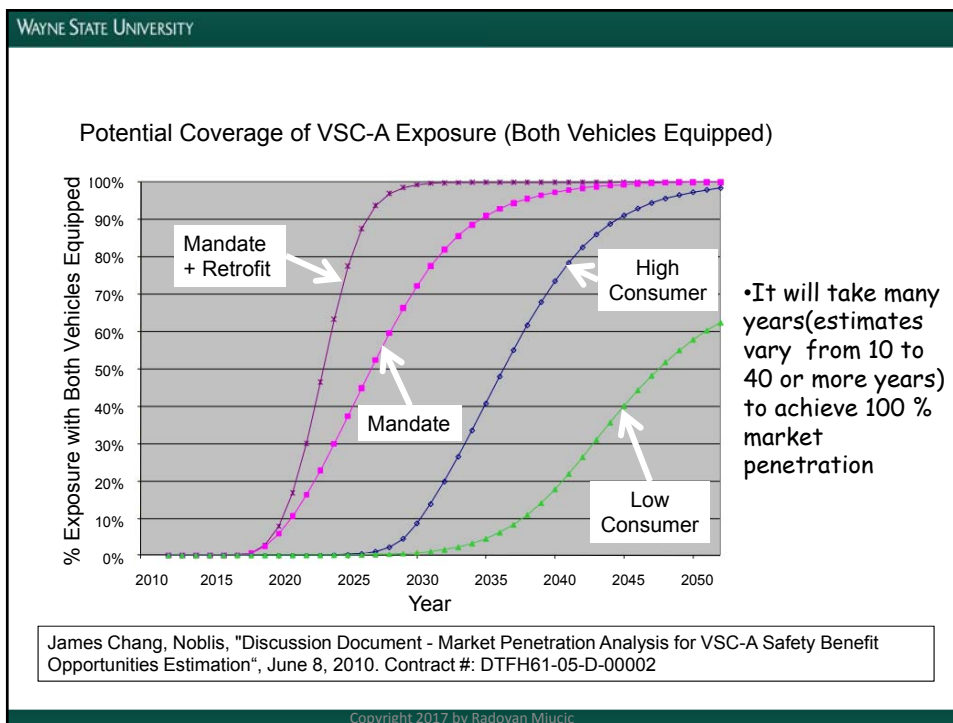
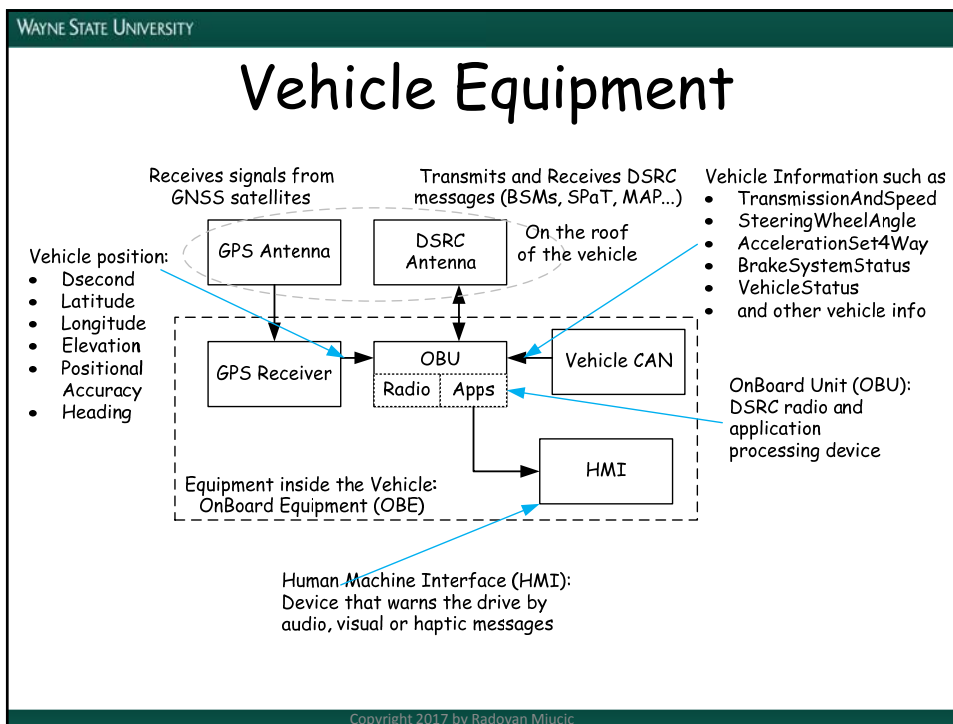

VANET Current and Future

- What about Cellular for V2X?
- Cellular community will find a technical solution for V2X. The question is **not if, but when.**

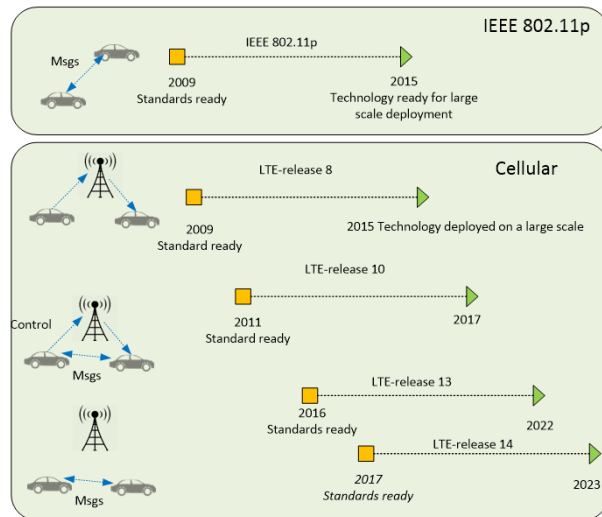

<http://www.automotive-eetimes.com/design-center/why-80211p-beats-lte-and-5g-v2x/>

Copyright 2017 by Radovan Mlucic

BSM Definition

Basic Safety Message (BSM)

The basic safety message (BSM) is used in a variety of applications to exchange safety data regarding vehicle state. This message is broadcast frequently (rate 10 times per second is typical) to surrounding vehicles with a variety of data content as required by safety and other applications. Part I data shall be included in every BSM. Part II data are optional for a given BSM and are included as needed according to policies. A BSM without Part II content is also a valid message.

Copyright 2017 by Radovan Mlucic

WAYNE STATE UNIVERSITY

BSM Part I and II

	Sub group	Element	Bytes	Required
PART I	Header	MsgCount	1	Y
		TemporaryID	4	Y
		DSecond	2	Y
	PositionLocal3D	Latitude	4	Y
		Longitude	4	Y
		Elevation	2	Y
		PositionalAccuracy	4	Y
		TransmissionAndSpeed	2	Y
	Motion	Heading	2	Y
		SteeringWheelAngle	1	Y
		AccelerationSet4Way	7	Y
	Control	BrakeSystemStatus	2	Y
	VehicleBasic	VehicleSize	3	Y
PART II	VehicleSafetyExtension	PathHistory	variable	Y
		PathPrediction		
		EventFlags		
VehicleStatus		variable	Optional	

Copyright 2017 by Radovan Miucic

WAYNE STATE UNIVERSITY

Always sent...

BSM PART I

Copyright 2017 by Radovan Miucic

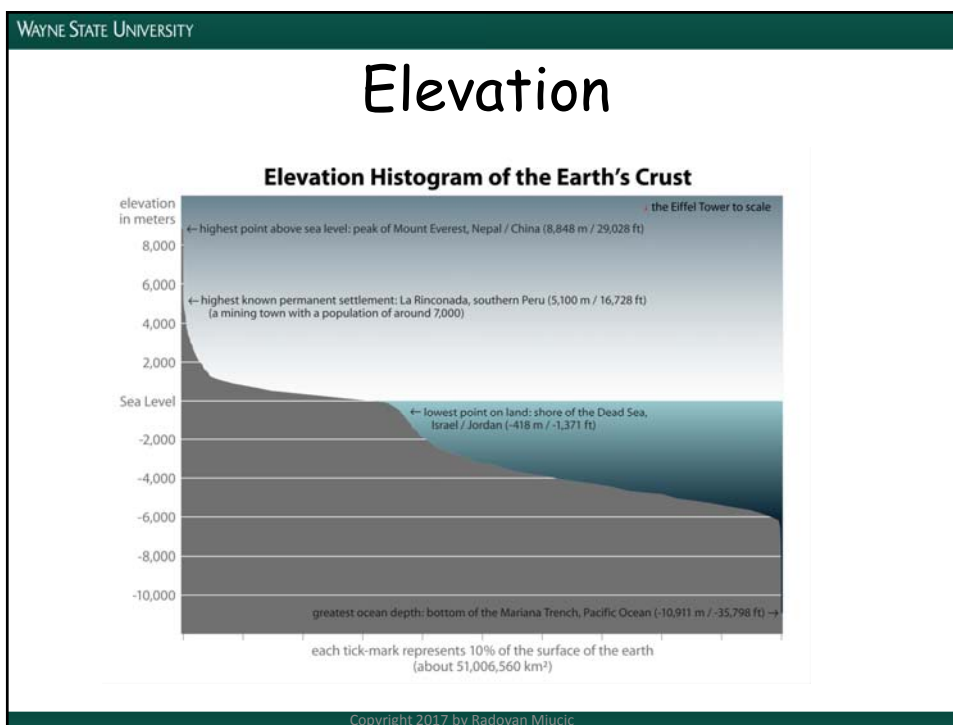
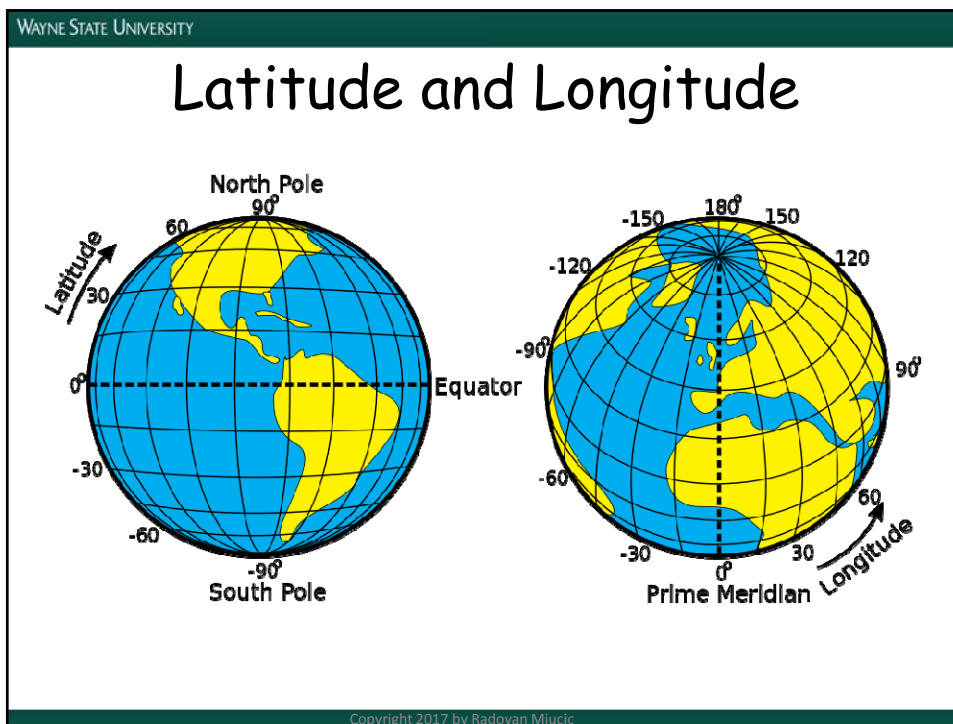

BSM Part I (Heading)

Heading

The current heading of the sending device, expressed in unsigned units of degrees from North. North shall be defined as the axis. Headings "to the east" are defined as the positive direction.

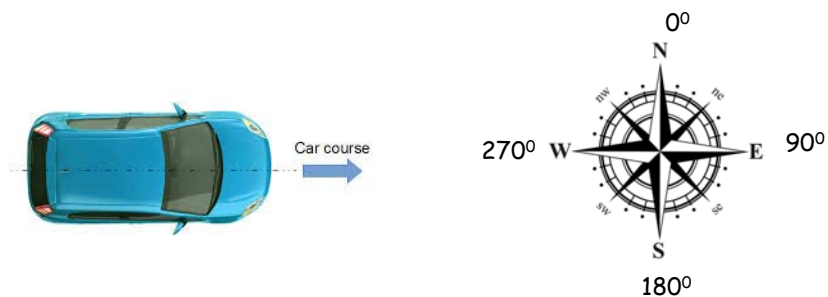

Copyright 2017 by Radovan Mlucic

BSM Part I (Transmission State and Speed)

Transmission State data element is used to provide the current state of the vehicle transmission:

- neutral
- park
- forward Gears
- reverseGears
- unavailable

Speed of the vehicle expressed in meters per second.



Copyright 2017 by Radovan Mlucic

BSM Part I (Steering Wheel Angle)

Steering Wheel Angle

The angle of the steering wheel, expressed in degrees

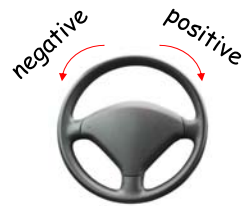

Copyright 2017 by Radovan Mlucic

Steering Wheel to Wheel Angle

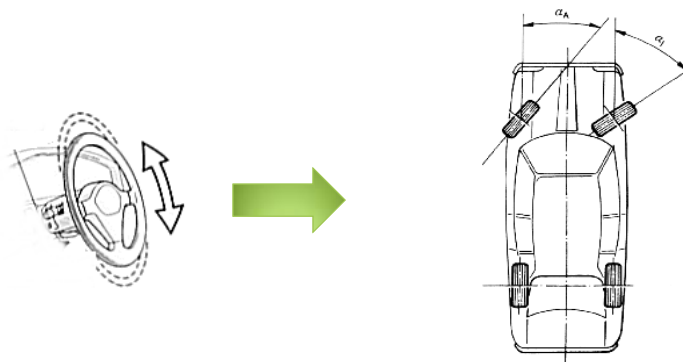

Copyright 2017 by Radovan Mlucic

SAE J670 Vehicle Axis System

- Yaw, Roll and Pitch rate
- All are in [deg/sec]

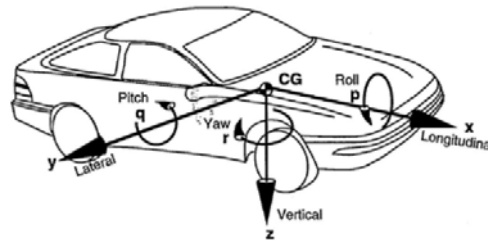

Vehicle Axis System

Copyright 2017 by Radovan Miuic

BSM Part I (Brake Status)

Brake Information

- **Brake Applied Status** data element indicates independently for each of four wheels whether braking is currently active.
- **Traction Control State** data element reflects the status of the vehicle traction system
- **Anti Lock Brake Status** data element conveys the state of the sender's anti-lock braking system.
- **Stability Control Status** reflects the current state of the stability control system status.
- **Stability Control Status**
- **Brake Boost Applied** indicates emergency braking.

Copyright 2017 by Radovan Miuic

BSM Part I (Vehicle Size)

Vehicle Width,
Vehicle Length

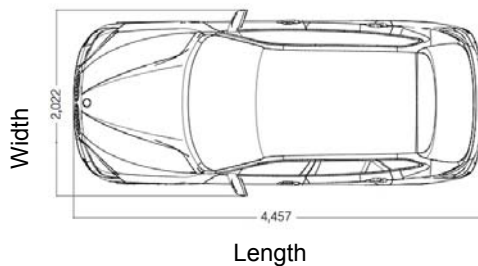

Some parts sent optionally, others triggered by events ...

BSM PART II

BSM Part II (VehicleSafetyExtension)

- **Event Flags**, element conveys the sender's state with regard to a set of events
- **Path History**, PathHistory data frame defines an adaptable set of PathHistoryPointSets reflecting recent vehicle movement over some period of time and/or distance.
- **Path Prediction**, frame allows vehicles to share their predicted path trajectory by estimating future vehicle path of travel.

BSM Part II(EventFlags)

The **Event Flags** data element conveys the sender's state with regard to a set of events. For each event, the sender has the option to set the flag to 1 if the stated criteria are met, but it is not required to do so. The set of event flags and their respective minimum criteria are listed in the next slide. The Event Flag data element should not be included in a Basic Safety Message unless at least one event flag is set to 1. When one or more criteria associated with an event are no longer satisfied the sender shall set the flag to zero in any Event Flag data element it sends. The presence of the Event Flag element in a message indicates that an unusual event has occurred. A vehicle receiving such a message might decide to process it differently than a message that does not include the Event Flag element. When a given event flag is set to 1 the message might include related optional data as well.

BSM Part II(EventFlags) cont.

Further normative definitions of when to assert each event are given below.

- Hazard Lights: The hazard lights are active.
- Stop Line Violation: The vehicle anticipates it will pass the line without coming to a full stop before reaching it.
- ABS: system activated exceeding 100 mSec in length and active
- Traction Control: system activated exceeding 100 mSec in length and active
- Stability Control: system activated exceeding 100 mSec in length and active
- Hazardous Materials: The vehicle known to be carrying hazardous material and is placarded as such.
- Emergency Response: The vehicle is a properly authorized public safety vehicle, is engaged in a service call, and is currently moving (lights and sirens may not be evident).
- Hard Braking: The vehicle has (or is) decelerated at a rate of greater than 0.4g
- Lights Changed: The status of the external lighting of the vehicle has changed recently (the new state of the lights is presented in another element).
- Wipers Changed: The status of wipers (front or rear) of the vehicle has changed recently (the new state of the wipers is presented in another element).
- Flat tire: The vehicle has determined that at least one tire has run flat.
- Disabled Vehicle: Any vehicle that considers itself disabled.
- Air Bag Deployment: At least one airbag has been deployed.

Copyright 2017 by Radovan Miucic

eventHardBraking Example

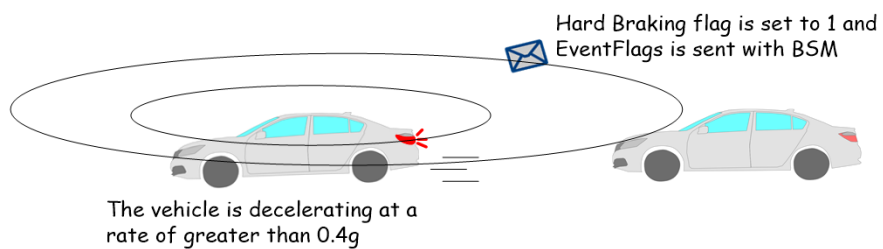

Copyright 2017 by Radovan Miucic

WAYNE STATE UNIVERSITY

Concise Representation of Path History

- Up to 23 PH points
- Up to 300m in length

Copyright 2017 by Radovan Mlucic

WAYNE STATE UNIVERSITY

BSM Part II (PathPrediction)

Path Prediction data frame allows vehicles to share their predicted path trajectory by estimating future vehicle path of travel. This future trajectory estimation provides an indication of future positions of the transmitting vehicle and can significantly enhance in-lane and out-of-lane threat classification. Trajectories in the Path Prediction data element are represented, at a first order of curvature approximation, as a circle with a radius R and an origin located at (O,R) , where the x-axis is bore sight from the transmitting vehicle's perspective and normal to the vehicle's vertical axis.

The radius can be derived from a number of sources including, but not limited to, map databases, rate sensors, vision systems, and global positioning, the precise algorithm to be used is outside the scope of this document.

Copyright 2017 by Radovan Mlucic

WAYNE STATE UNIVERSITY

Path Prediction and Path History

Path History Points

Radius of Curvature

Path Prediction

$$R = v_x / \omega$$

R Radius of Curvature
 v_x Longitudinal velocity
 ω Yaw rate (radians per second)

(0,R)

Copyright 2017 by Radovan Miucic

WAYNE STATE UNIVERSITY

Cooperative Vehicular Safety Applications

Prepared by Radovan Miucic

Copyright 2017 by Radovan Miucic

VSC-A Video Vehicle-to-Vehicle Safety Applications

<https://youtu.be/PEHrXmfQyQA>

Motivation

- Fatality Analysis Reporting System (FARS) for National Safety Highway Administration (NHTSA)
 - <http://www-fars.nhtsa.dot.gov/Main/index.aspx>
- National Safety Council (NSC) Motor Vehicle Fatality Estimate
 - <http://www.nsc.org/NewsDocuments/2017/12-month-estimates.pdf>

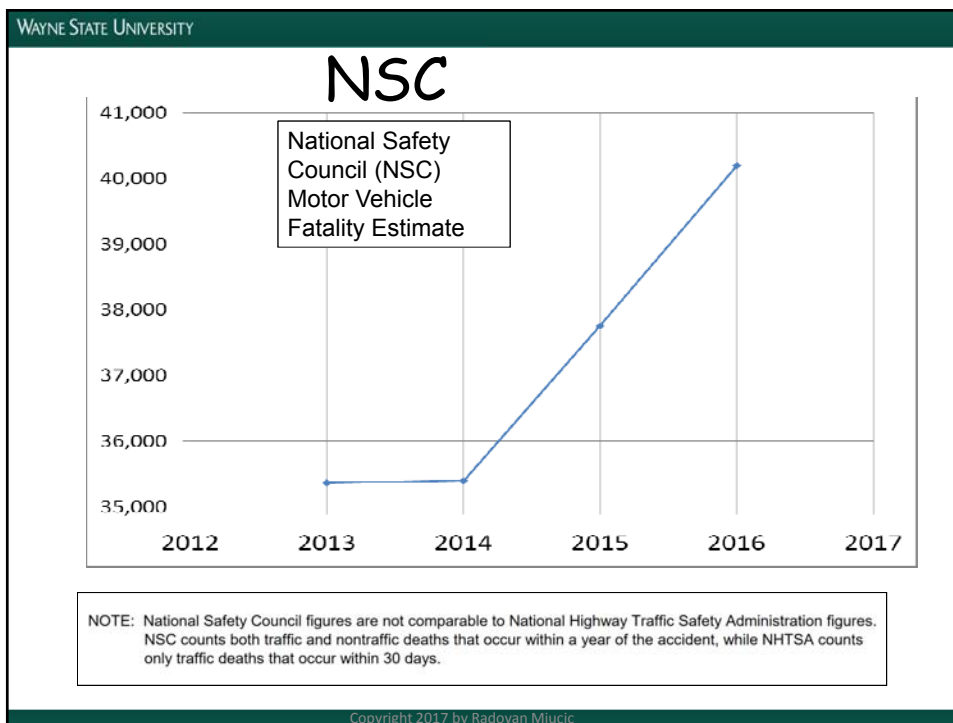
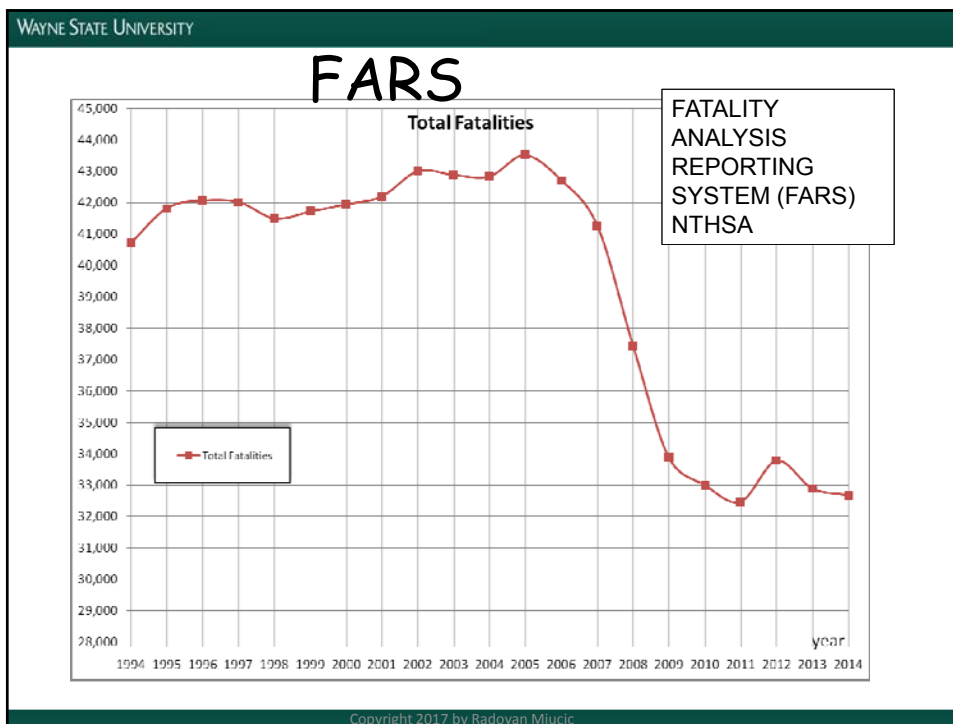

Communication Requirements

- Share current position, speed, accelerations, brake, throttle, path history and path prediction
- High availability
- Low latency (100 ms) for V2V and V2I
- Security:
 - exchange of msgs has to be authentic, privacy has to be present, and the mesgs must be trustworthy
- Extensible
 - Design need to accommodate improvements and changes

Vehicular Positioning

- Global Navigation Satellite Systems
 - Operational
 - GPS (USA)
 - GLONASS (Russia)
 - In Development
 - Beidou (China)
 - Galileo (EU)
 - IRNSS (India)
- Positioning Requirements for VSC-A
 - needs to be lane level (with in 1.5 m)

Vehicle Safety Communications-Applications

Based on US Government statistics on crash frequency, cost, and functional years lost VSC-A identified seven safety applications:

- **Emergency Electronic Brake Lights (EEBL):**
 - Warns of sudden braking of vehicles in the forward path.
- **Forward Collision Warning (FCW):**
 - Warns of impending rear-end collision with forward vehicle.
- **Blind Spot Warning (BSW)/Lane Change Warning (LCW):**
 - Warns during a lane-change attempt if there is another vehicle moving in the same direction (or soon will be in) the blind spot. Secondary advisory whenever there is a vehicle in the blind spot.
- **Intersection Movement Assist (IMA):**
 - Warns when it is not safe to enter intersection.
- **Do Not Pass Warning (DNP):**
 - Warns when oncoming vehicle poses collision threat if a lane change is attempted.
- **Control Loss Warning (CLW):**
 - Self-generated warning when vehicle loses control. Other vehicles will be warned depending on the threat.

Copyright 2017 by Radovan Miucic

Vehicle Safety Communications-Applications

Based on US Government statistics on crash frequency, cost, and functional years lost VSC-A identified seven safety applications:

- **Emergency Electronic Brake Lights (EEBL):**
 - Warns of sudden braking of vehicles in the forward path.
- **Forward Collision Warning (FCW):**
 - Warns of impending rear-end collision with forward vehicle.
- **Blind Spot Warning (BSW)/Lane Change Warning (LCW):**
 - Warns during a lane-change attempt if there is another vehicle moving in the same direction (or soon will be in) the blind spot. Secondary advisory whenever there is a vehicle in the blind spot.
- **Intersection Movement Assist (IMA):**
 - Warns when it is not safe to enter intersection.
- **Do Not Pass Warning (DNP):**
 - Warns when oncoming vehicle poses collision threat if a lane change is attempted.
- **Control Loss Warning (CLW):**
 - Self-generated warning when vehicle loses control. Other vehicles will be warned depending on the threat.

Copyright 2017 by Radovan Miucic

WAYNE STATE UNIVERSITY

Emergency Electronic Brake Lights (EEBL)

- Host vehicle monitors BSMs from other vehicles ahead and in the same lane
- Host vehicle provides warning to driver when he is in danger of rear-end collision with vehicle ahead in lane in advance

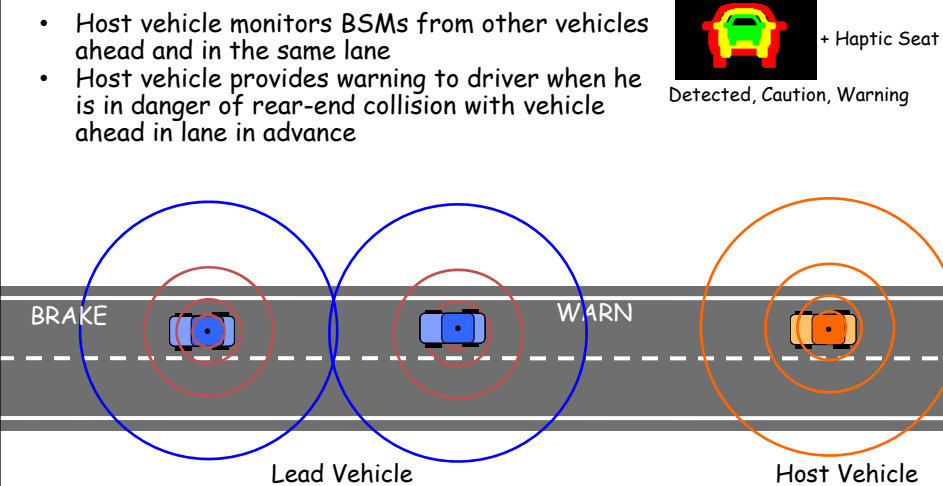

Detected, Caution, Warning

Lead Vehicle

Host Vehicle

Copyright 2017 by Radovan Mlucic

WAYNE STATE UNIVERSITY

Forward Collision Warning (FCW)

- Host vehicle monitors BSMs from other vehicles ahead and in the same lane
- Host vehicle provides warning to driver when he is in danger of rear-end collision with vehicle ahead in lane

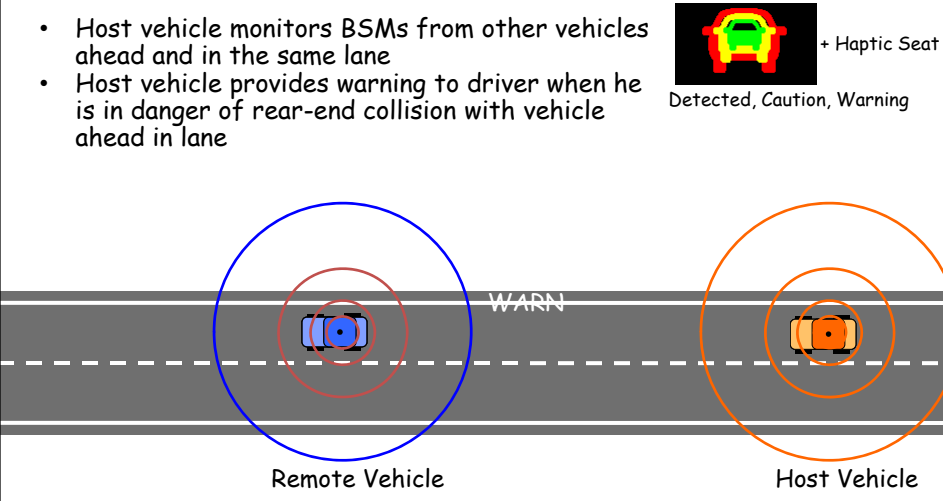

Detected, Caution, Warning

Remote Vehicle

Host Vehicle

Copyright 2017 by Radovan Mlucic

WAYNE STATE UNIVERSITY

Blind Spot Warning (BSW)

- Host vehicle provides advisory (steady amber) to the driver when there is a vehicle in blind zone
- Host vehicle provides warning (flashing amber + haptic seat) to the driver when there is a vehicle in blind zone and turn lamp is activated

Blind Zone

Host Vehicle Remote Vehicle

Copyright 2017 by Radovan Mlucic

WAYNE STATE UNIVERSITY

Lane Change Warning - Closing Vehicle

- Host vehicle warns (flashing amber) when there is another overtaking vehicle in next lane and turn lamp is activated

Fast Approach Zone

Host Vehicle Remote Vehicle

Copyright 2017 by Radovan Mlucic

WAYNE STATE UNIVERSITY

Slow / Stopped Vehicle Advisor

- Host vehicle monitors messages from other vehicles up to 250m ahead
- Host vehicle advises driver when any vehicle ahead (in lane, right / left lane) is stopped or traveling 20 mph slower than the host

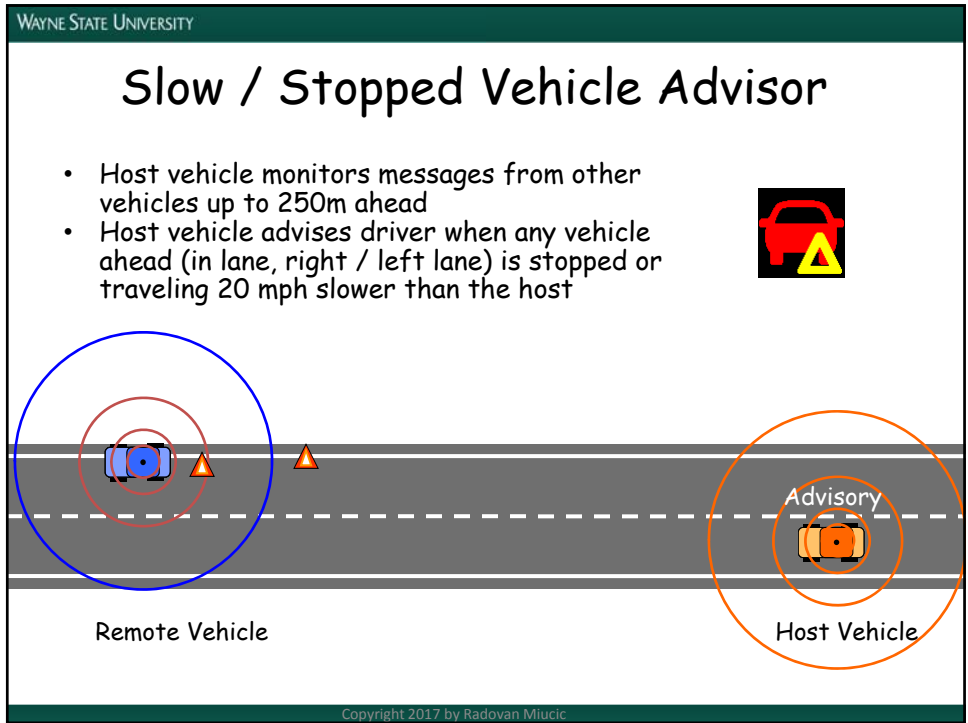

The diagram shows a two-lane road with a dashed center line. On the left, a blue car labeled 'Remote Vehicle' is surrounded by concentric red and blue circles representing its detection range. Two orange triangles are positioned ahead of it. On the right, an orange car labeled 'Host Vehicle' is shown with a red car icon and a yellow triangle warning symbol above it, indicating an advisory. The word 'Advisory' is written above the orange car.

Remote Vehicle

Host Vehicle

Copyright 2017 by Radovan Mlucic

WAYNE STATE UNIVERSITY

Intersection Movement Assist (IMA)

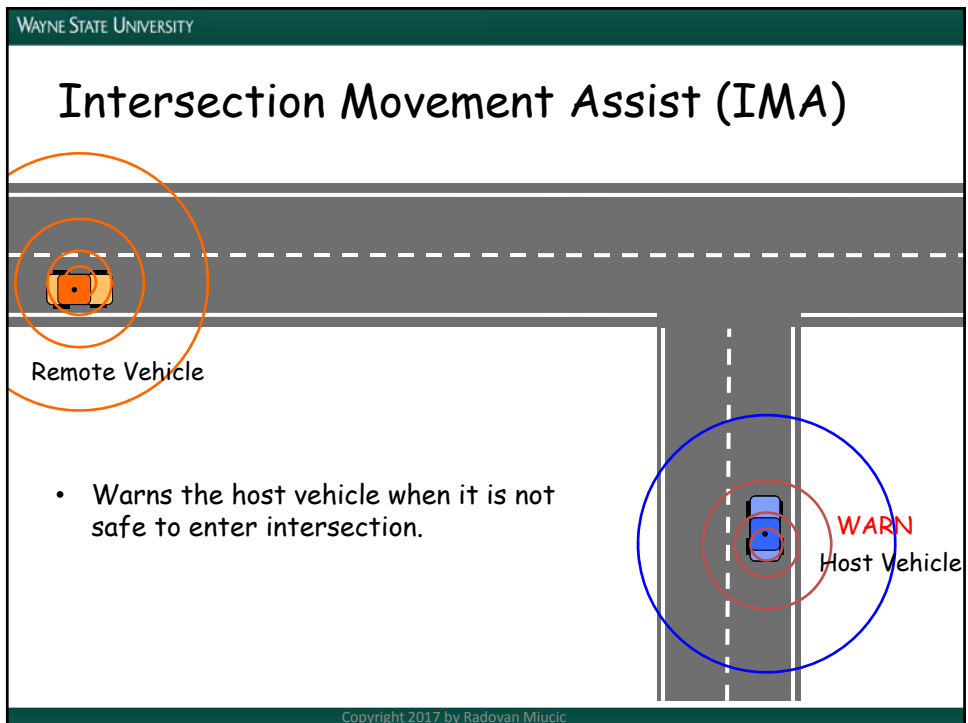

The diagram shows a T-junction intersection. A blue car labeled 'Remote Vehicle' is on the left side of the road, approaching the intersection. An orange car labeled 'Host Vehicle' is on the right side of the road, also approaching the intersection. A red 'WARN' symbol is placed next to the host vehicle, indicating a warning. Concentric circles around the host vehicle represent its detection range.

- Warns the host vehicle when it is not safe to enter intersection.

Remote Vehicle

Host Vehicle

Copyright 2017 by Radovan Mlucic

WAYNE STATE UNIVERSITY

Control Loss Warning (CLW)

- Host vehicle monitors BSMs from other vehicles ahead and in the same or adjacent lanes
- Host vehicle provides warning to driver when he is in danger of rear-end collision with vehicle ahead in the same or adjacent lanes

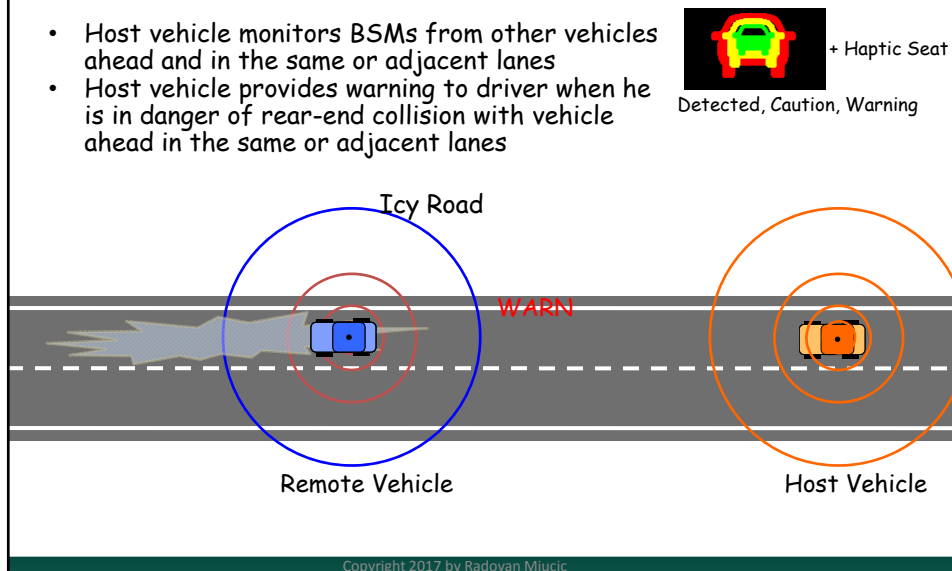

Copyright 2017 by Radovan Mlucic

WAYNE STATE UNIVERSITY

Do Not Pass Warning (DNP)

- Host vehicle monitors BSMs from other vehicles ahead and in the opposite direction adjacent lane
- Host vehicle provides warning to driver when he is in danger of head on collision with vehicle in the opposite lane

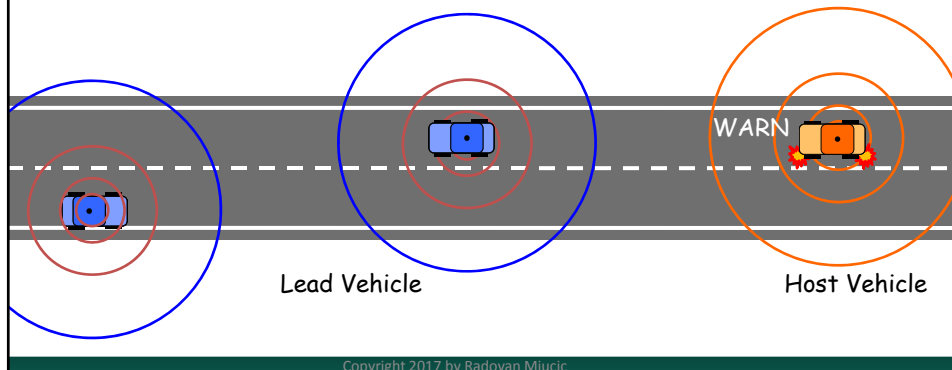

Copyright 2017 by Radovan Mlucic

Performance Metrics

- Packet Delivery Ratio (PDR)
 - PDR is the probability of successful packet delivery.
 - PDR is calculated at the receiver and it a ratio of the number of packets transmitted at transmitter (TX) and number of packets received at receiver (RX)
 - Inter Packet Gap (IPG) is defined as the time between successive successful receptions of messages sent by a specific transmitter.
 - Received Signal Strength Indicator (RSSI) is an indication of the power level being received by the antenna.
 - The higher the RSSI number, the stronger the signal.
 - In dBm.
- PDR, IPG, RSSI can be expressed as function of TX-RX, distance, number of TX nodes, environment (such as line of site, non line of site, urban or rural) etc.

Copyright 2017 by Radovan Mlucic

VSC-A System Test Bed

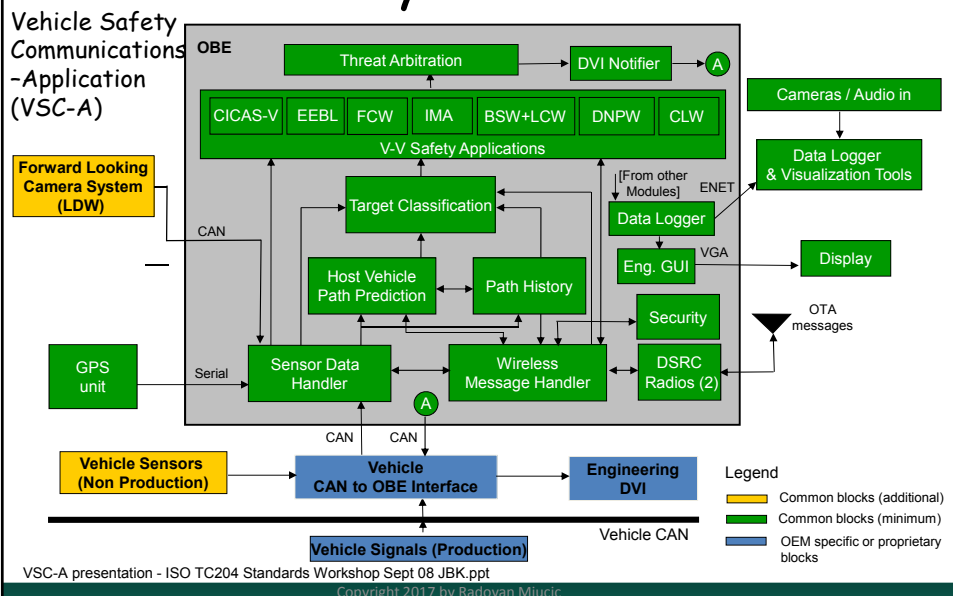

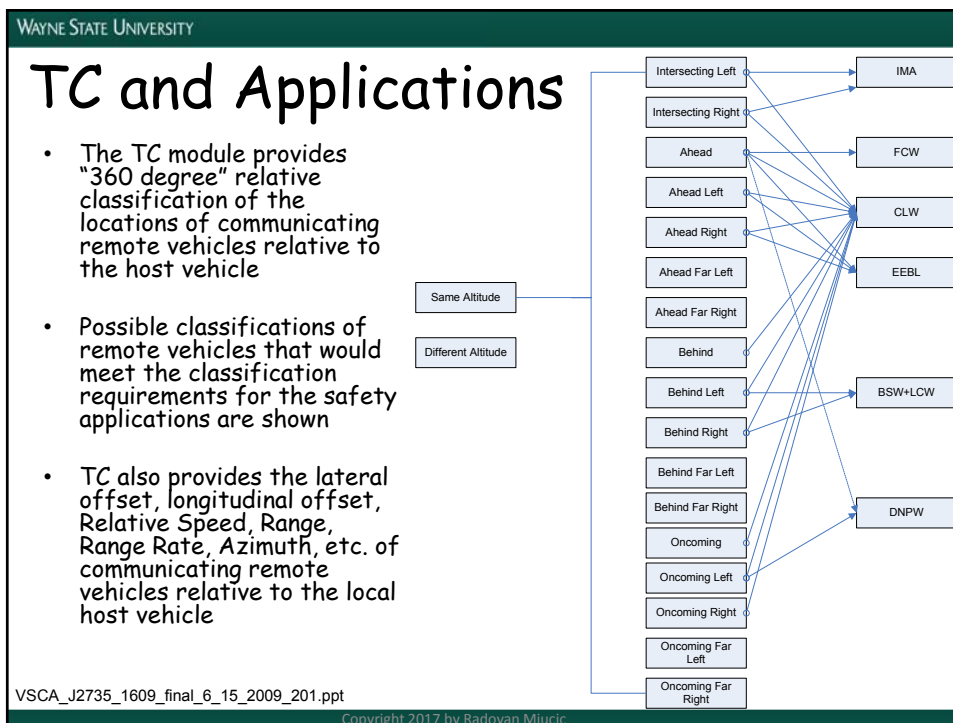
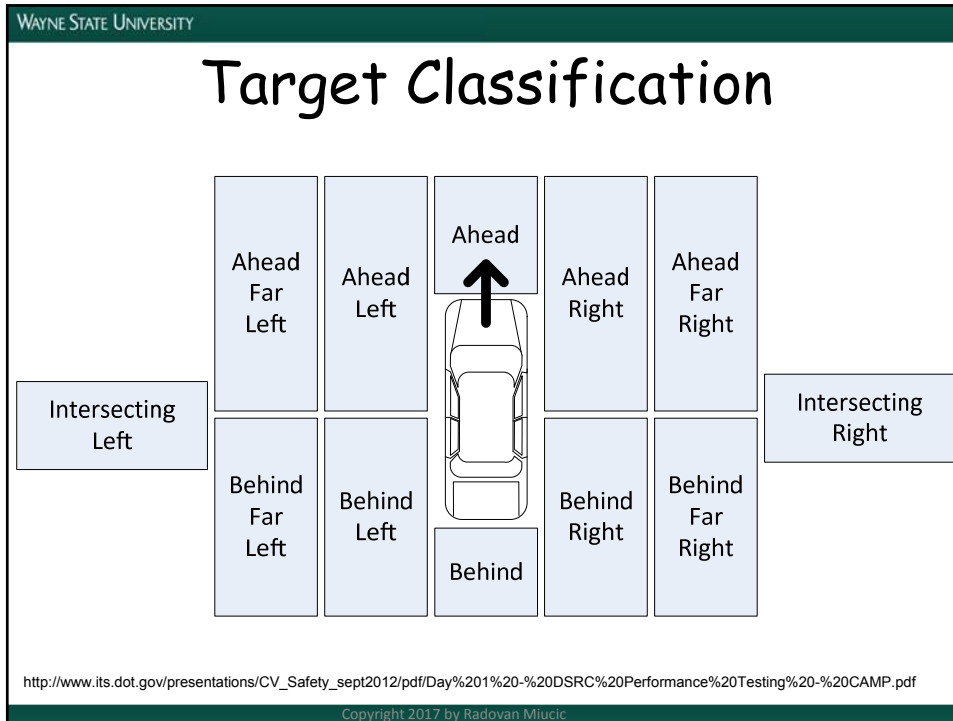

Vehicle to Pedestrian

Prepared by Radovan Miucic

Vehicle 2 Pedestrian

Cooperative Safety Application between vehicle and pedestrian (smartphone).

- Vehicle and smartphone exchange Over the air msgs
- <https://youtu.be/fc1X4M96ins>

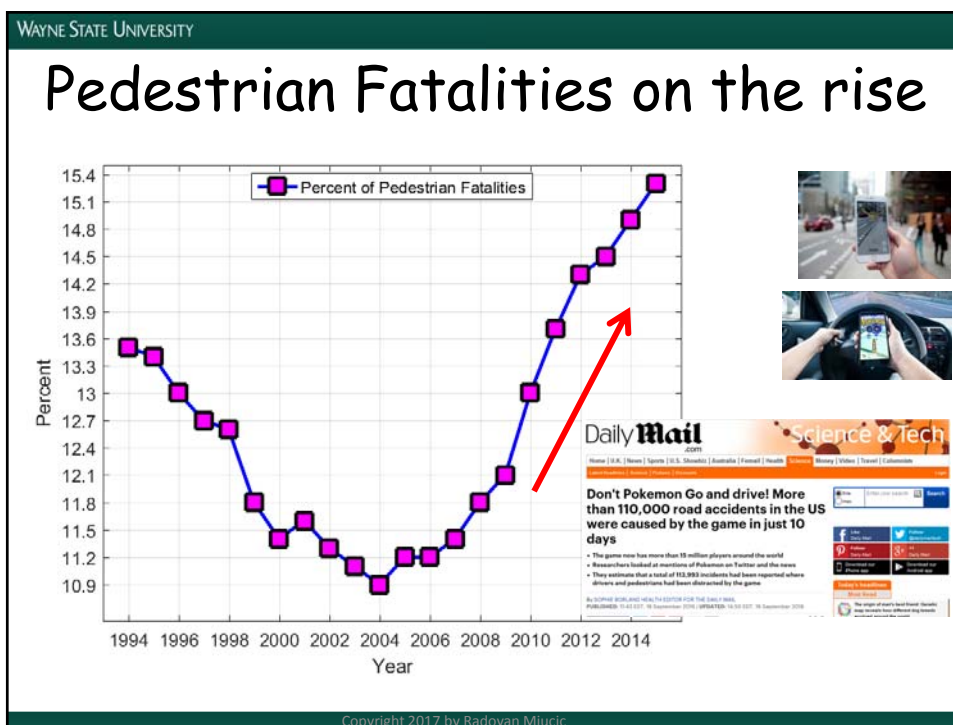
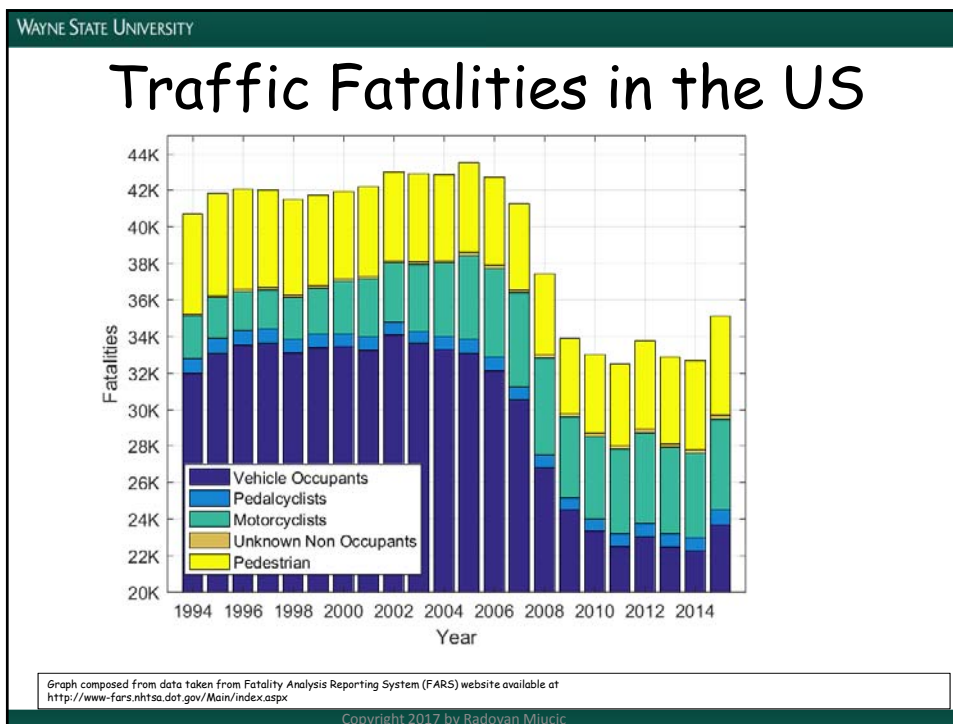

WAYNE STATE UNIVERSITY

Critical Scenarios

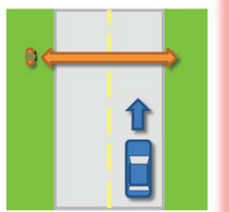

Scenario S1

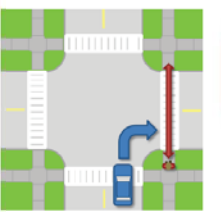

Scenario S2



Scenario S3

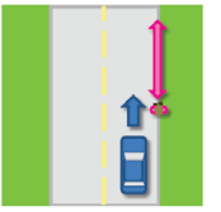

Scenario S4

Scenario	Cases	% All FYL	Fatalities
S1	115,000	84%	7,000
S2	2,000	1%	16
S3	9,000	1%	0
S4	13,000	10%	1,000

Taken from "Objective Tests for Forward Looking Pedestrian Crash Avoidance/Mitigation Systems - Final Report" available at http://www.nhtsa.gov/DOT/NHTSA/NVS/Crash%20Avoidance/Technical%20Publications/2014/812040_CAMP_FLV_MitigationReport%20.pdf

Copyright 2017 by Radovan Mlucic

WAYNE STATE UNIVERSITY

V2P Application Strategy

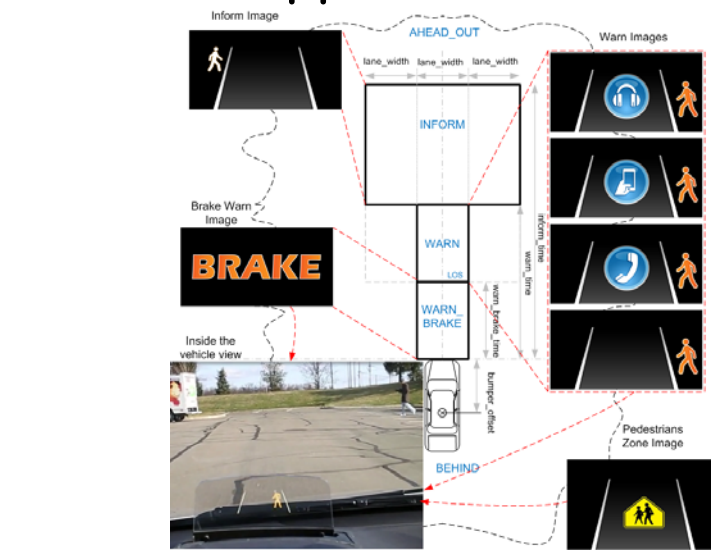

Mlucic, R. "Vehicle-to-Pedestrian Cooperative Safety Application," Intelligent Transportation System World Congress, 2014.

Copyright 2017 by Radovan Mlucic

WAYNE STATE UNIVERSITY

V2P - Animation

The diagram illustrates the V2P (Vehicle-to-Pedestrian) communication process. It starts with an **Inform Image** showing a pedestrian on a road. This leads to a central processing unit with three levels of alert: **INFORM**, **ALERT**, and **WARN**. The **INFORM** level is associated with the **AHEAD_OUT** state and lane width parameters. The **ALERT** level is associated with the **BEHIND** state and bumper offset. The **WARN** level is associated with the **BEHIND** state and bumper offset. A **Brake Warn Image** with the word **BRAKE** is shown. On the right, **Alert Images** are shown, including icons for a smartphone, headphones, and a phone receiver. A **Heads Up Display** view shows a pedestrian on the road with a **BEHIND** label. The diagram is credited to SAE INTERNATIONAL and Copyright 2017 by Radovan Mlucic.

SAE INTERNATIONAL
Heads Up Display
Copyright 2017 by Radovan Mlucic

WAYNE STATE UNIVERSITY

Phone Side Warning

The image shows three examples of phone side warnings. The first is a yellow and black striped background with a car icon and the text **WATCH OUT**. The second is a yellow and black striped background with the text **VEHICLE BACKING UP**. The third is a smartphone screen displaying the **QVling** app interface. The app shows a car icon and the text **SELF(Movement): undetermined**. Below this, it displays safety information: **SAFETY: GREEN from 2014-02-24T15:48:35** and **Distraction: Music = false, Text = false, phone =**. The app interface also includes buttons for **Exit**, **End Monitoring**, and **Enable Walking**. The image is credited to Xinzhou Wu, Mlucic, R., Sichao Yang, Al-Stouhi, S., Misener, J., Sue Bai, Wai-hoi Chan, "Cars Talk to Phones: A DSRC Based Vehicle-Pedestrian Safety System," Vehicular Technology Conference (VTC Fall), 2014 IEEE 80th, vol., no., pp.1,7, 14-17 Sept. 2014 and Copyright 2017 by Radovan Mlucic.

Xinzhou Wu, Mlucic, R., Sichao Yang, Al-Stouhi, S., Misener, J., Sue Bai, Wai-hoi Chan, "Cars Talk to Phones: A DSRC Based Vehicle-Pedestrian Safety System," Vehicular Technology Conference (VTC Fall), 2014 IEEE 80th, vol., no., pp.1,7, 14-17 Sept. 2014
Copyright 2017 by Radovan Mlucic

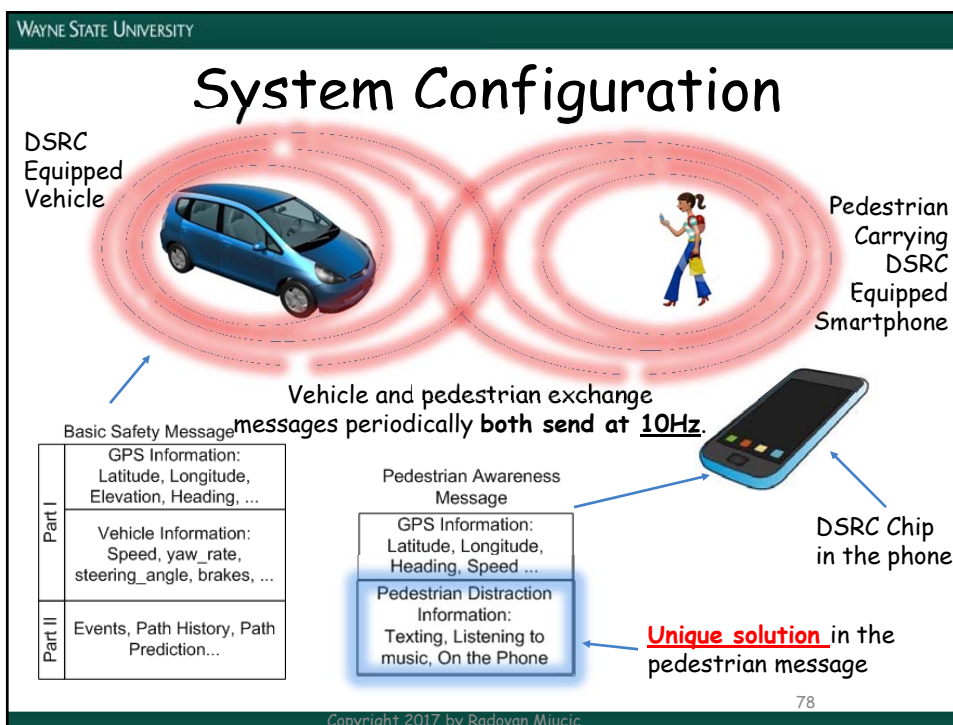
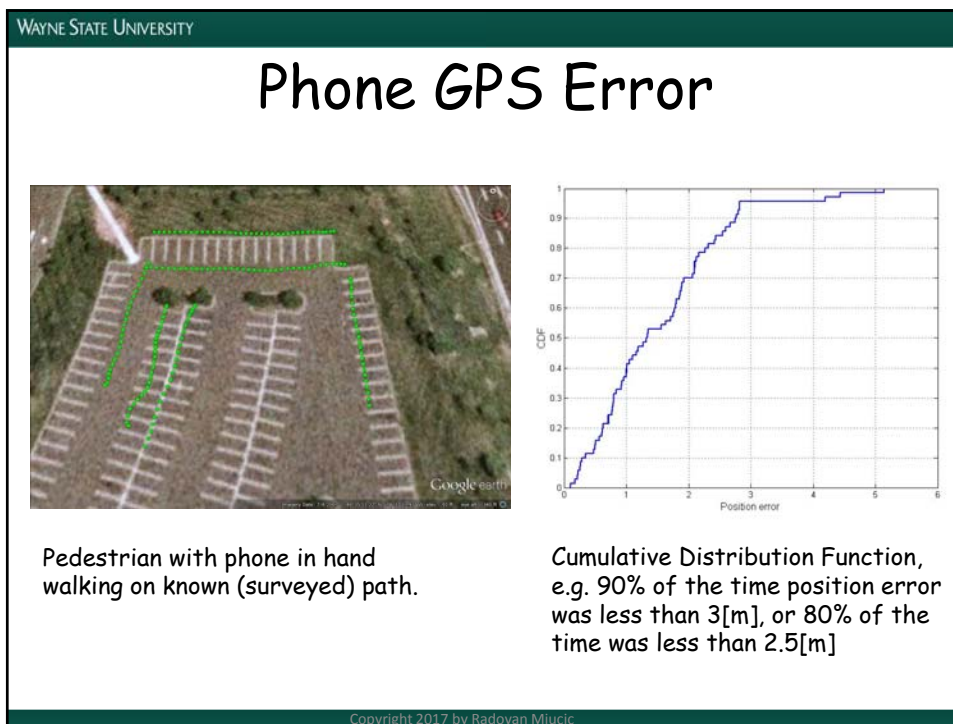

Performance Metrics

- Packet Delivery Ratio (PDR)
 - PDR is the probability of successful packet delivery.
 - PDR is calculated at the receiver and it a ratio of the number of packets transmitted at transmitter (TX) and number of packets received at receiver (RX)
 - Inter Packet Gap (IPG) is defined as the time between successive successful receptions of messages sent by a specific transmitter.
 - Received Signal Strength Indicator (RSSI) is an indication of the power level being received by the antenna.
 - The higher the RSSI number, the stronger the signal.
 - In dBm.
- PDR, IPG, RSSI can be expressed as function of TX-RX, distance, number of TX nodes, environment (such as line of site, non line of site, urban or rural) etc.

Copyright 2017 by Radovan Mlucic

RSSI and IPG

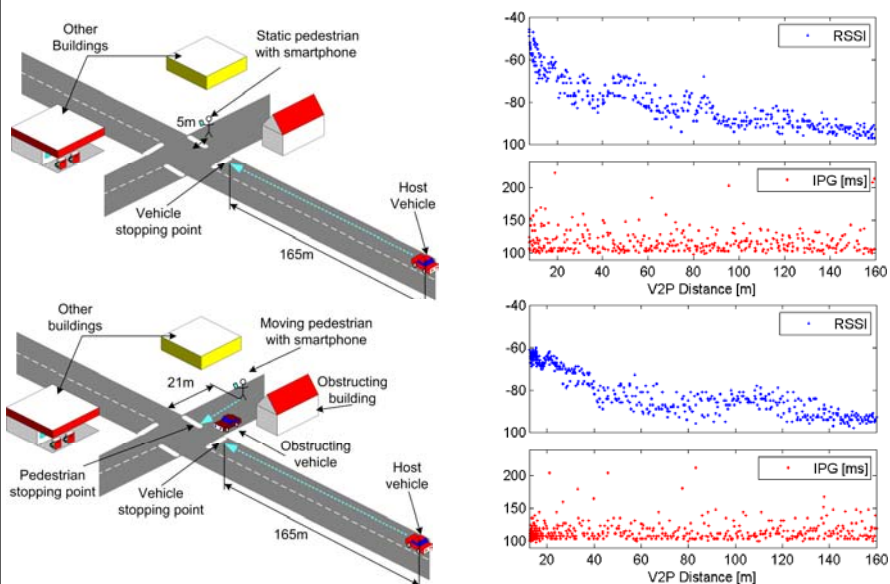

Copyright 2017 by Radovan Mlucic

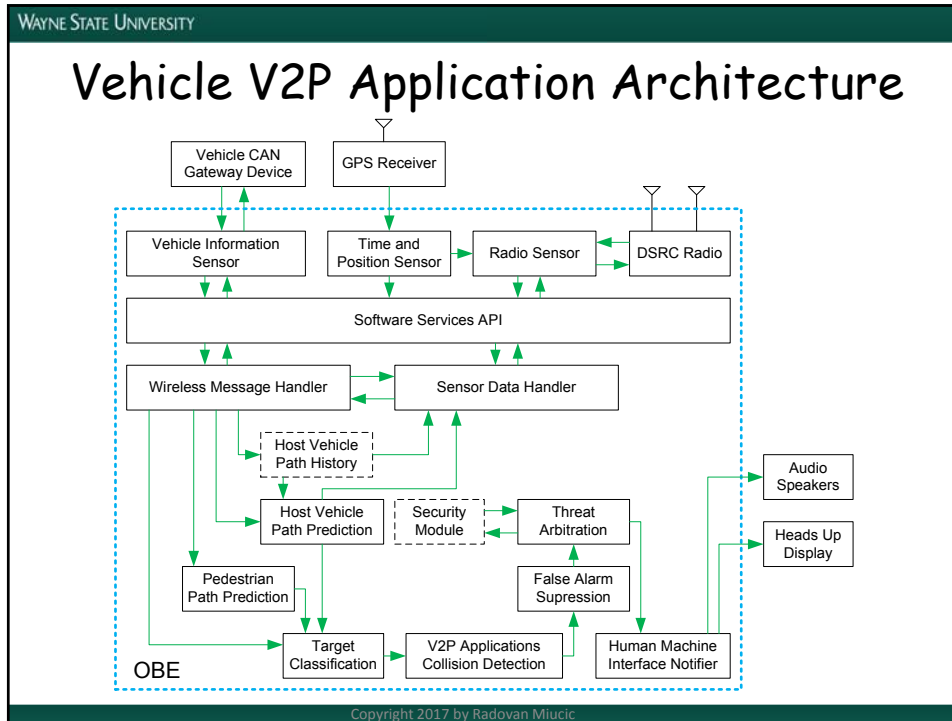

WAYNE STATE UNIVERSITY

V2P Challenges: Mobile Positioning Accuracy

- Effective V2P application depends on good relative positioning between vehicles and pedestrians.
- Smartphones acquire position every seconds (at the current prototype messages are exchanged every 100ms)
- Accuracy need improvement
 - e.g. 90% of the time position error was less than 3[m], or 80% of the time was less than 2.5[m]

Copyright 2017 by Radovan Mlucic

V2P Challenges: Security Design

- Vehicle security is based on the public-key infrastructure and applied at four stages: bootstrapping, certificate provisioning, misbehavior reporting and revocation.
- Smartphones are always connected to the infrastructure, allowing for an easier security management.
 - smartphone security must be compatible with the vehicle

Vehicle to Infrastructure Safety Application

Prepared by Radovan Miucic

Vehicle to Infrastructure Videos

- Consumers Report Video
<https://youtu.be/QB8XoHMZc8U>
- GAO: Vehicle-to-Infrastructure Safety Applications
<https://youtu.be/Ke7LdyOnjLw>

Intersection Crashes

- In the US annually
 - 1.72 million intersection crashes
 - 9000 fatalities
- Stop sign and traffic signal violations
 - 302,000 crashes (250,000 running red light)
 - \$7.9 billion economic loss

CICAS-V

- Cooperative Intersection Collision Avoidance System for Violation (CICAS-V) project
 - (2006-2009)
 - US DOT and 5 major OEMs collaboration
- CICAS-STLA - Signalized left turn assistance
- CICAS-SSA - Stop Sign Assistance

Cooperative Intersection Collision Avoidance System for Violation CICAS-V

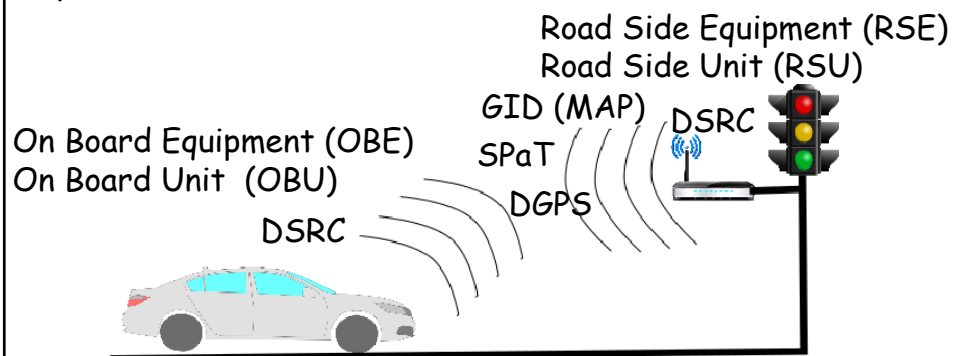

- Geometric Intersection Description(GID)/MAP message
- Differential corrections for Global Positioning Sys. (DGPS)
- Signal Phase and Timing (SPaT)

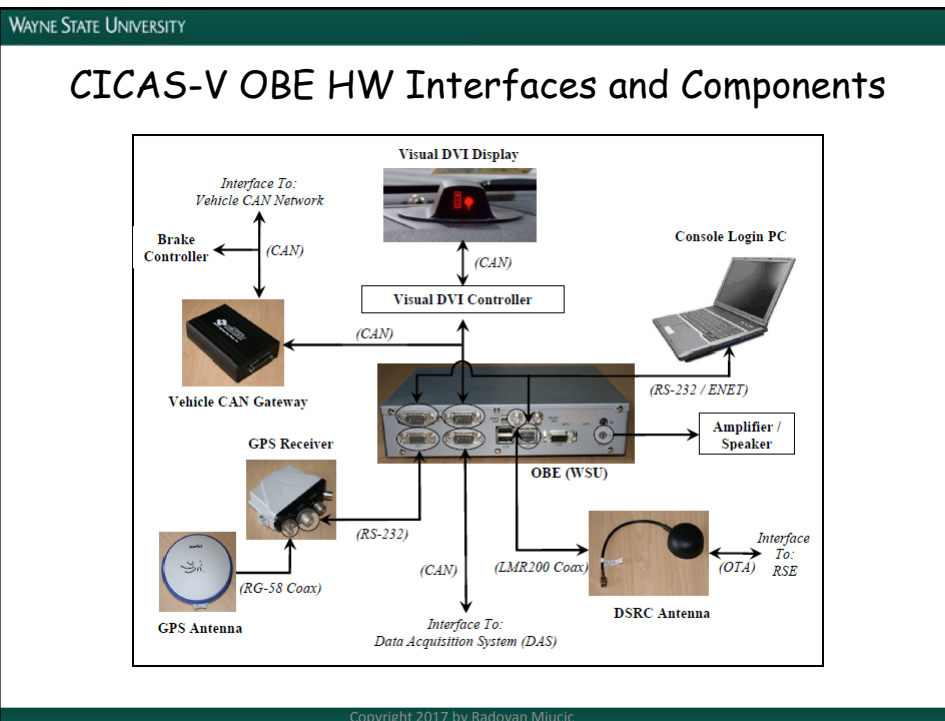
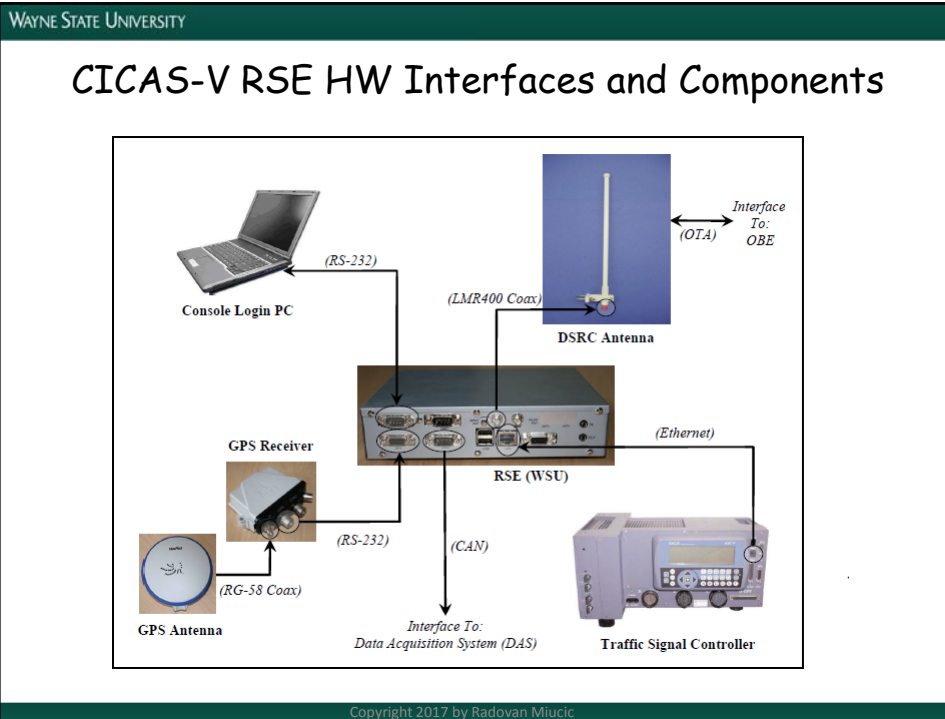

Vehicular Positioning

Prepared by Radovan Miucic

Vehicle Positioning

- Global Positioning System (GPS):
 - For military and civilian use
 - ~30 (at least 24 95% time) satellites orbiting the earth
 - Low power radio signals from satellites
 - Receives determines Time of Arrival (TOA) and performs ranging
 - Almanac coarse position of the satellites
 - Ephemeris used to compute precise position of each satellite.
 - Broadcast CDMA on two freq. L1(1575.42MHz) and L2(1227.6MHz)
 - Can achieve sub meter accuracy for commercial receivers

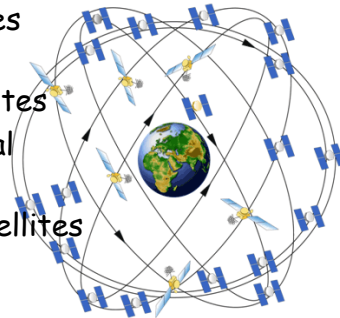

WAYNE STATE UNIVERSITY

Vehicle Positioning ... cont

Sat. Transmitted data:

- Navigation data enables receiver to determine location of satellite at the time of transmission
- Ranging codes enables receiver to determine propagation time
- 4 satellites are needed for a GPS solution:
 - 3 for ranging + 1 to resolve time due imperfect clocks in the GPS receivers

Copyright 2017 by Radovan Mlucic

WAYNE STATE UNIVERSITY

Vehicle Positioning ... cont

- GPS requires Line of Sight between receiver and the satellites
- Signals from some or all satellites may be lost if the vehicle is in the urban canyon, due to heavy foliage, tunnel, etc.
- Modern vehicles temporary relay on dead reckoning when GPS is lost.
- Dead reckoning uses data from vehicle sensors such as wheel speed, yaw rate, steering wheel angle, inertial sensor and map matching.
- Dead reckoning may be sufficient for few minutes for navigation purposes but may not be sufficient for VSC-apps.

Copyright 2017 by Radovan Mlucic

Positioning Accuracy

- Road level - "Which Road" the vehicle is traveling on (5m or better)
- Lane level - "Which Lane" the vehicle is traveling on (1.5m-half lane width or better)
- Navigation Applications require road level accuracy
- Safety Applications require lane level accuracy
- GPS Improvements (sub meter acc.):
 - Differential GPS (DGPS)
 - WAAS
 - RTK GPS (relative GPS)

Vehicular Positioning

- Global Navigation Satellite Systems
 - Operational
 - GPS (USA)
 - GLONASS (Russia)
 - In Development
 - Beidou (China)
 - Galileo (EU)
 - IRNSS (India)
- Positioning Requirements for VSC-A
needs to be lane level (within 1.5 m)

What is the Global Positioning System

- U.S. military system
 - Conceived in 1960
 - First satellites launched in 1978
 - Fully operational in April 1995
- GPS consists of 24 satellites
 - Each one circle the globe once every 12 hours
- GPS makes it possible to precisely identify locations on the earth by measuring distance from the satellites.

Copyright 2017 by Radovan Mlucic

Three Segments of the GPS

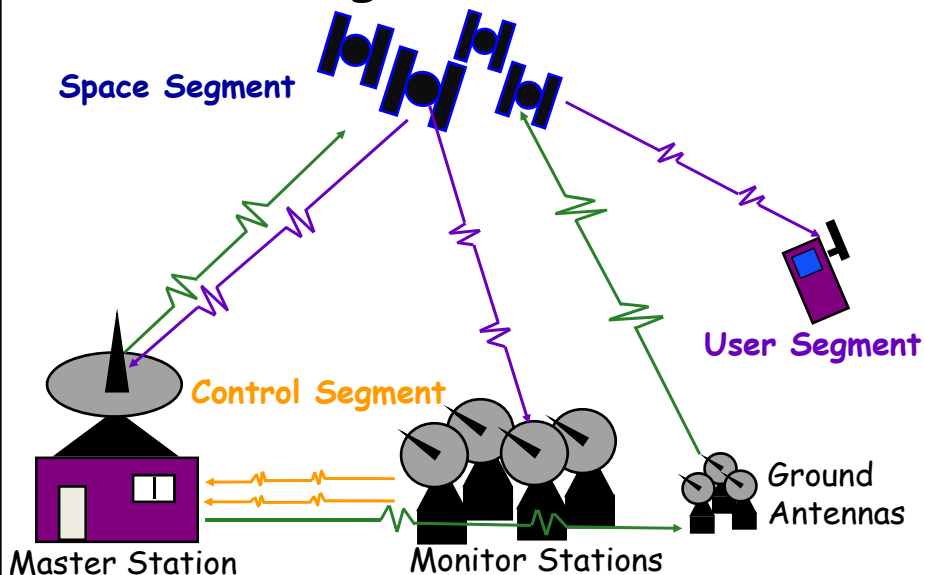

Copyright 2017 by Radovan Mlucic

The 3 segments of GPS

- (1) Space segment
 - 24 satellites circling the earth at 12,000 miles in altitude
 - orbits arranged such that GPS receiver on earth can always receive a signal from at least 4 satellites at any given time
 - satellite transmits low radio signals
 - with a unique code on different frequencies, allowing the GPS receiver to identify the signals.
 - coded signals is to allow for calculating travel time from the satellite to the GPS receiver.
 - The travel time multiplied by the speed of light equals the distance from the satellite to the GPS receiver.
 - important to have a clear view of the sky

The 3 segments of GPS (cont.)

- (2) The Control segment
 - tracks the satellites and then provides them with corrected orbital and time information.
- (3) The User segment:
 - The user segment consists of the users and their GPS receivers.
 - The number of simultaneous users is limitless.

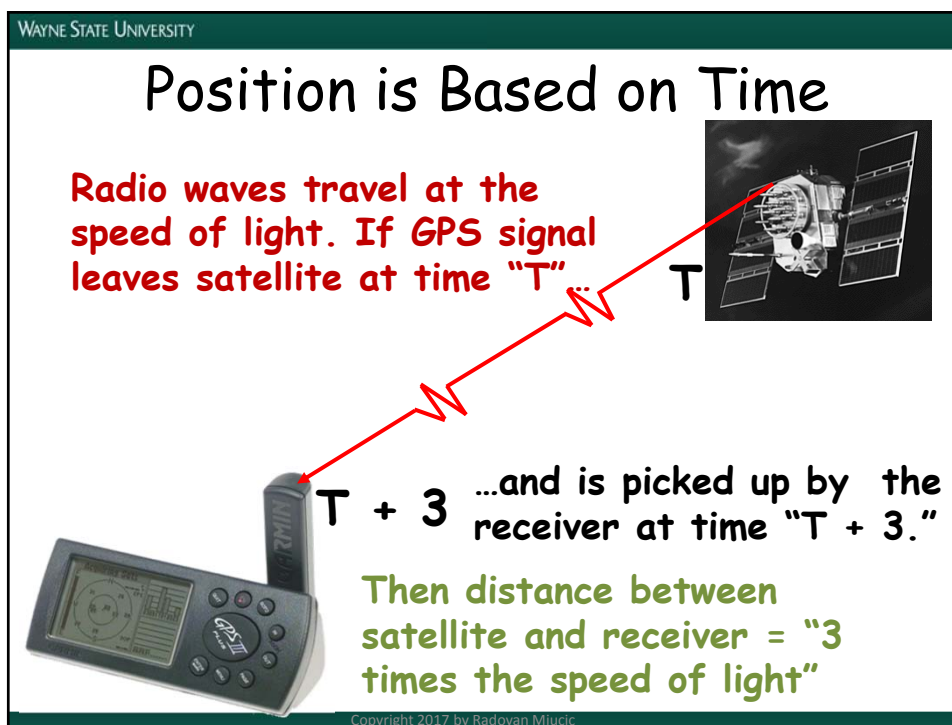
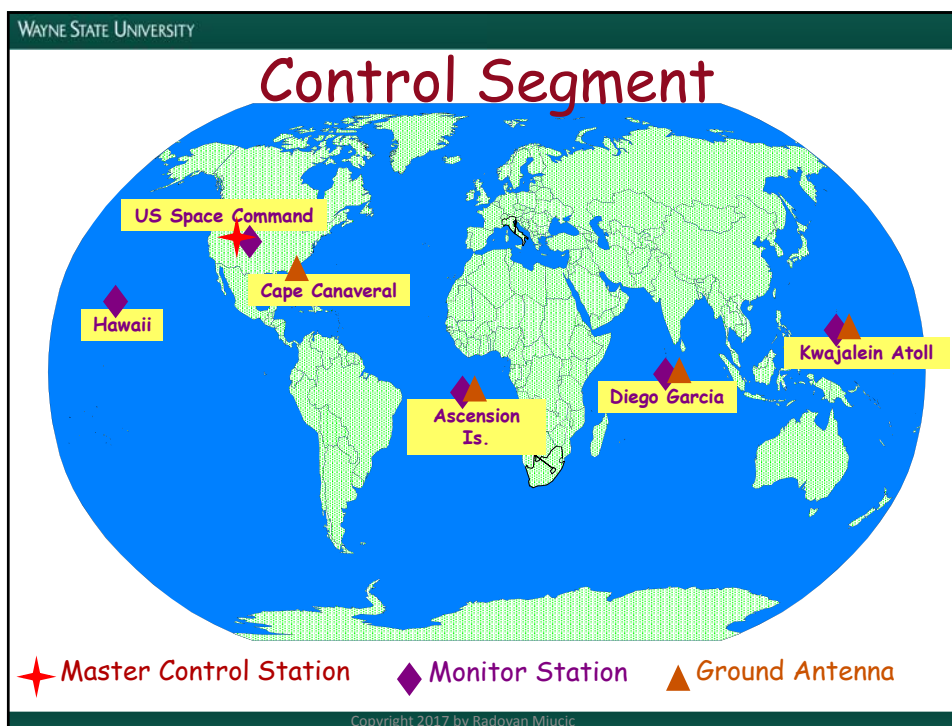

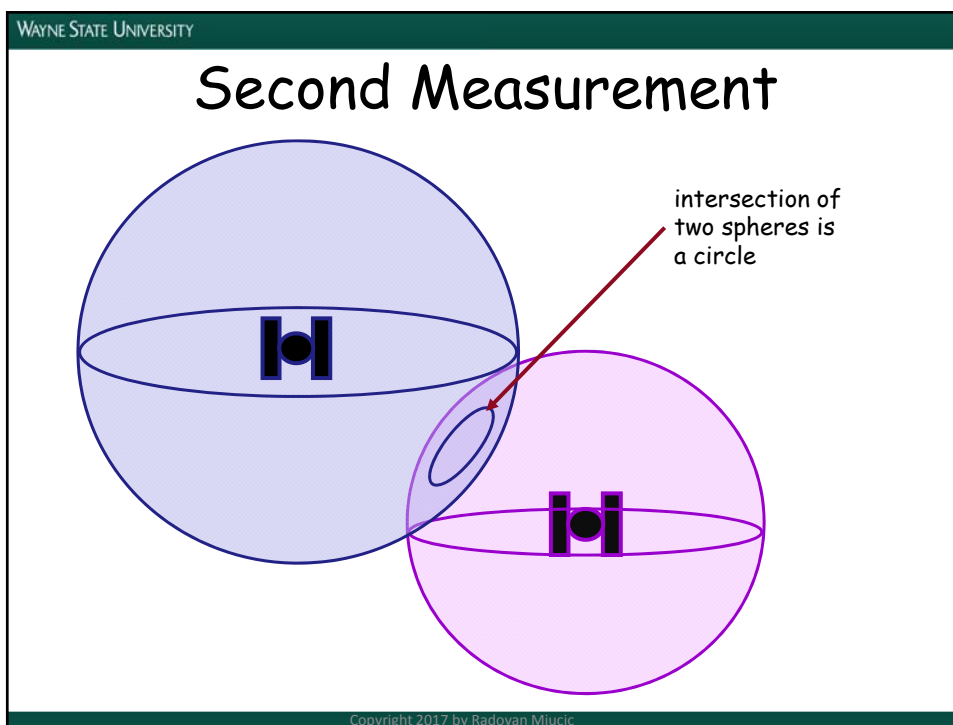
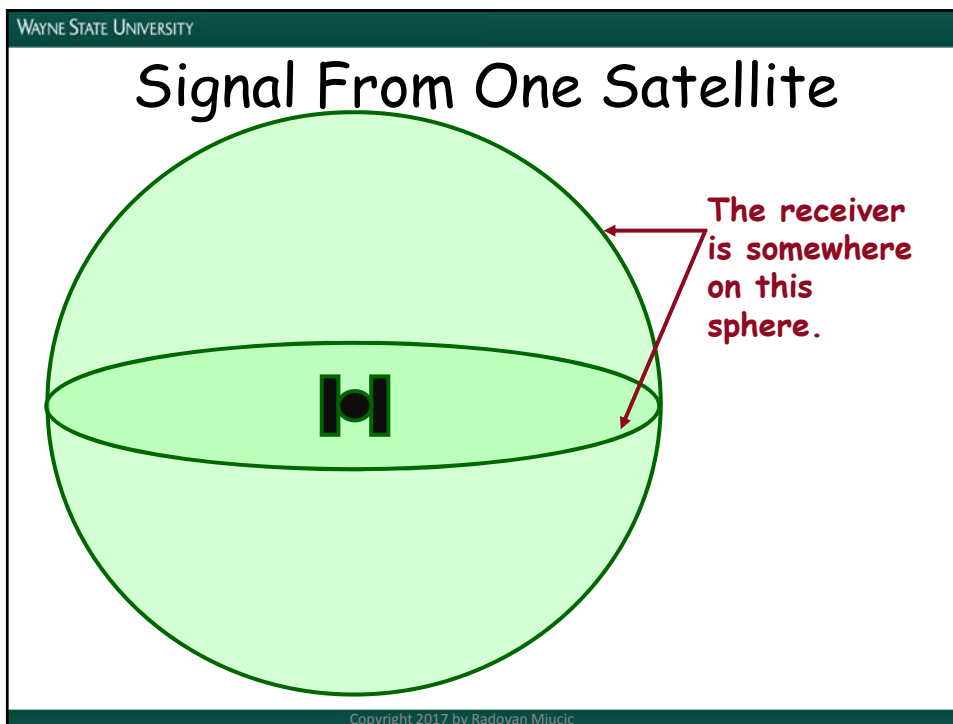

WAYNE STATE UNIVERSITY

Third Measurement

intersection of three spheres is only two points

Copyright 2017 by Radovan Mucic

Detailed description: This diagram shows three overlapping spheres. The leftmost sphere is blue, the top-right one is green, and the bottom-right one is purple. Each sphere contains a stylized 'H' logo. A red arrow points from the text 'intersection of three spheres is only two points' to two yellow dots located at the intersection of all three spheres. The spheres are semi-transparent, showing their internal structures.

WAYNE STATE UNIVERSITY

Forth Measurement

Forth measurement will only go through one of the two points

Copyright 2017 by Radovan Mucic

Detailed description: This diagram shows four overlapping spheres: blue (left), green (top-right), purple (bottom-right), and orange (bottom-left). Each sphere contains a stylized 'H' logo. A red arrow points from the text 'Forth measurement will only go through one of the two points' to one of the two yellow dots at the intersection of all four spheres. The spheres are semi-transparent, showing their internal structures.

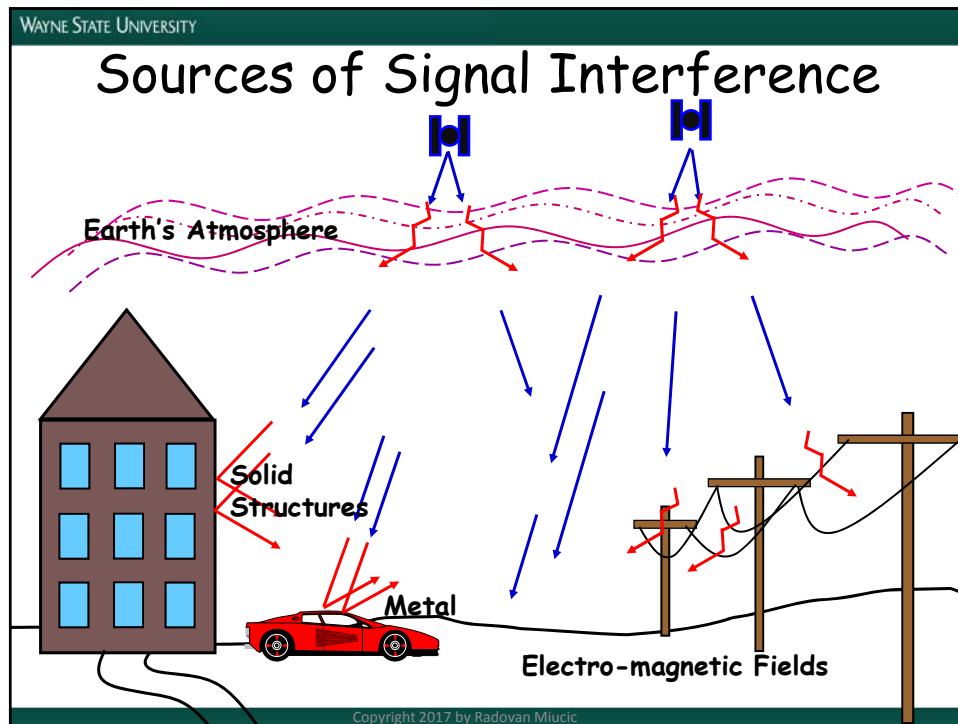

WAYNE STATE UNIVERSITY

Positioning Improvements

Positioning improvements

- Differential *GPS* (DGPS)
 - Ground reference station of a know location calculates pseudo-range corrections for each satellite and wirelessly transmits the corrections to the vehicles.
 - E.g. NDGPS (National DGPS) run by Coast Guard and the U.S. Department of Transp.
- Wide Area Augmentation System (WAAS)
 - Developed by the Federal Aviation Administration
 - uses a network of ground-based reference stations (20 in US). They monitor and calculate *GPS* corrections in the different area (continental US). The corrections are then sent to satellites and satellites rebroadcast that information.
- Visual Odometry
 - Using camera to enhance position

Copyright 2017 by Radovan Mlucic

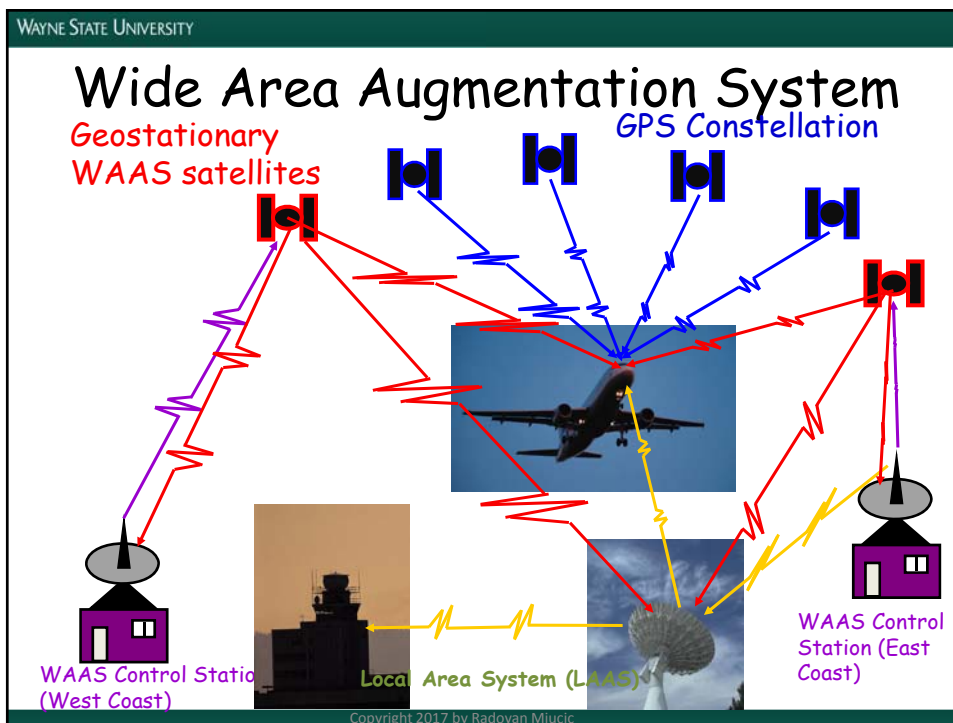
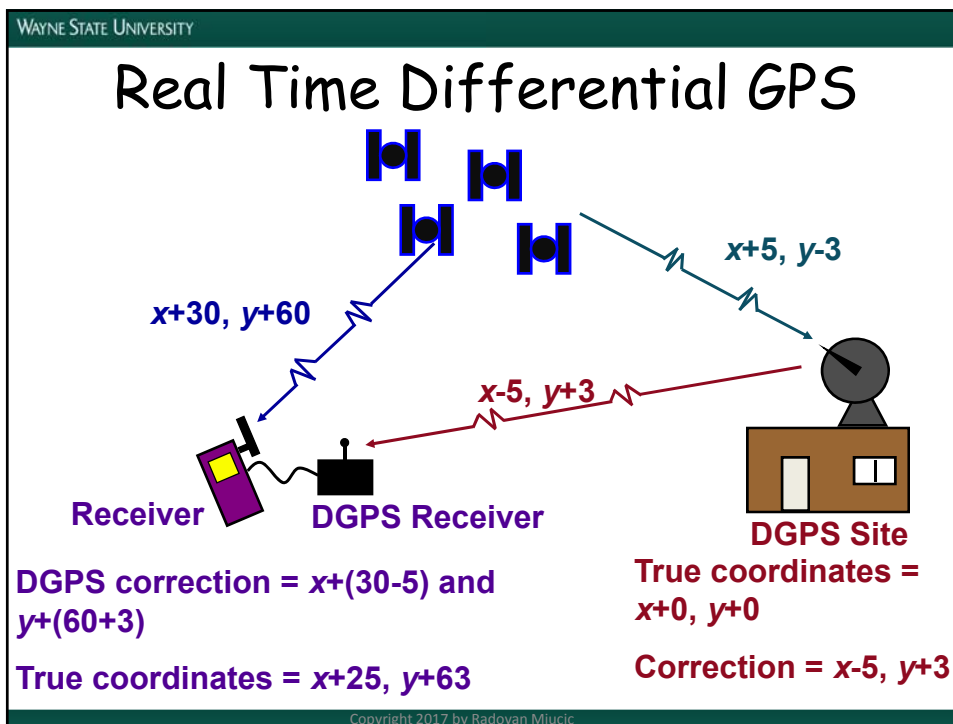

Positioning Improvements

- Inertial Measurement Unit (IMU)
 - is an electronic device that measures and reports changes in a vehicles velocity, orientation, and gravitational forces, it can use a combination of accelerometers and gyroscopes, sometimes also magnetometers.
 - If used as a standalone suffers from position drifts.
 - GPS/IMU/other vehicle sensors integration improves position solution and bridges the gap between GPS signal outages (enhancing dead reckoning)
 - Fiber optics based IMUs are high accuracy but currently cost prohibitive for vehicles
 - MEMS based IMUs are cheaper but lower accuracy

Positioning Improvements

- Real Time Kinematic (RTK)
 - Uses phase lock loops on the carrier waves
 - Suffers from lock slippage when the line of between vehicle and a satellite sight is lost
- Wireless Ranging
 - Using wireless signal (WiFi, LTE) to trilaterate position from known locations of base stations

GPS Almanac

- The almanac consists of
 - ephemeris data: orbit (current and predicted) and status information for each satellite in the constellation,
 - an ionospheric model, and
 - information to relate GPS derived time to Coordinated Universal Time (UTC).
- Complete almanac is transmitted by each satellite

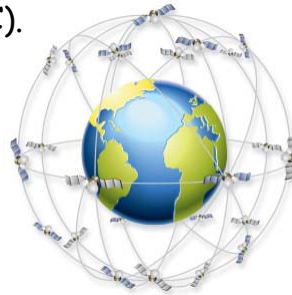

Copyright 2017 by Radovan Miucic

Connected and Autonomous Vehicle

Prepared by Radovan Miucic

Copyright 2016 by Radovan Miucic

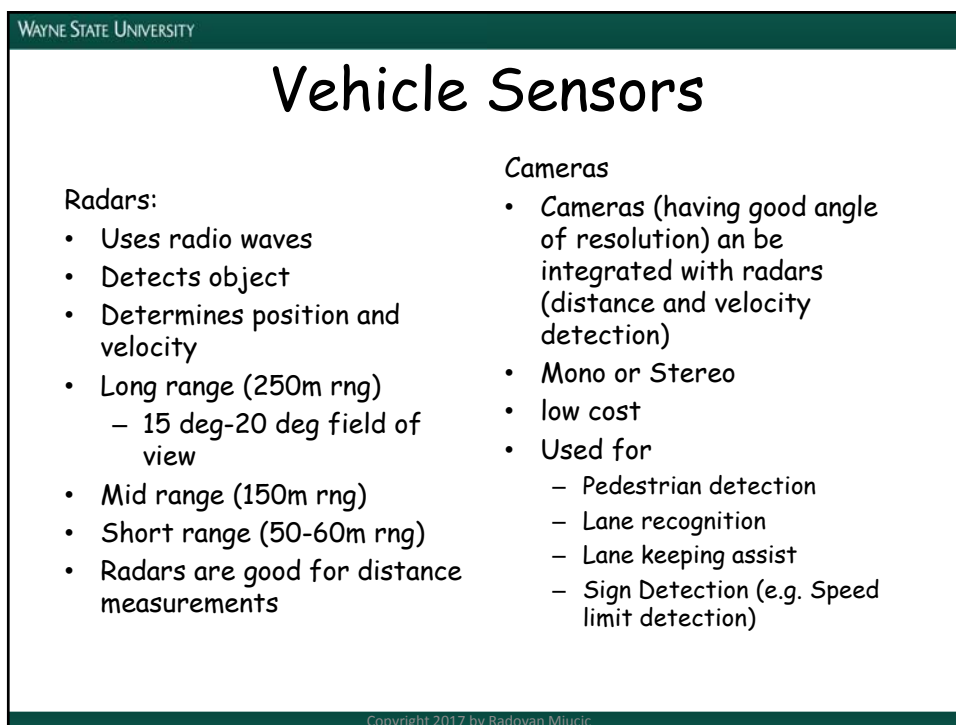
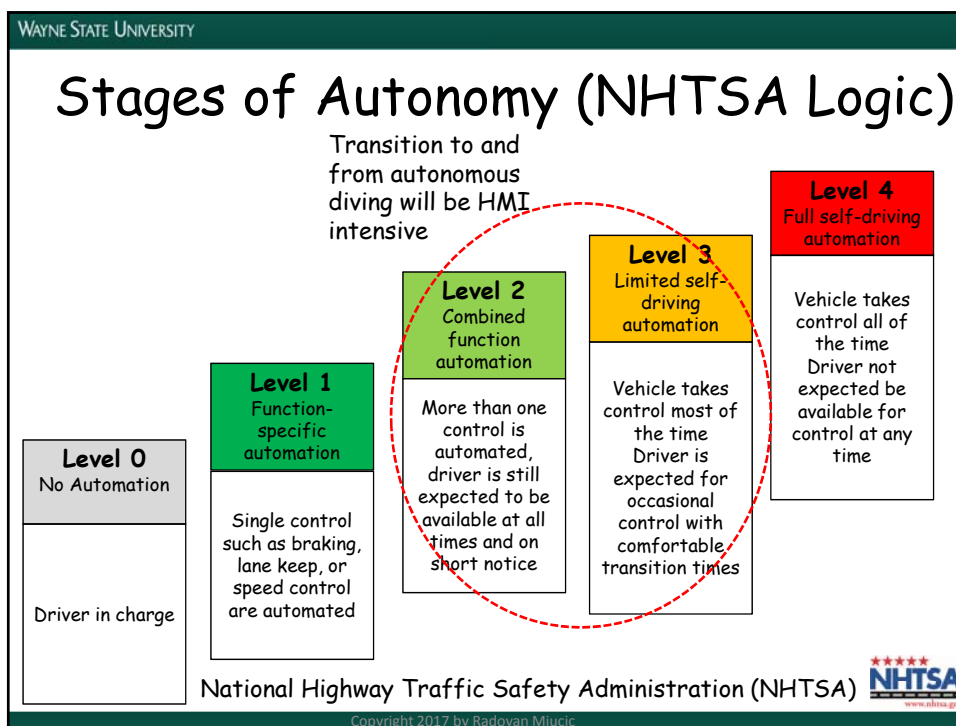

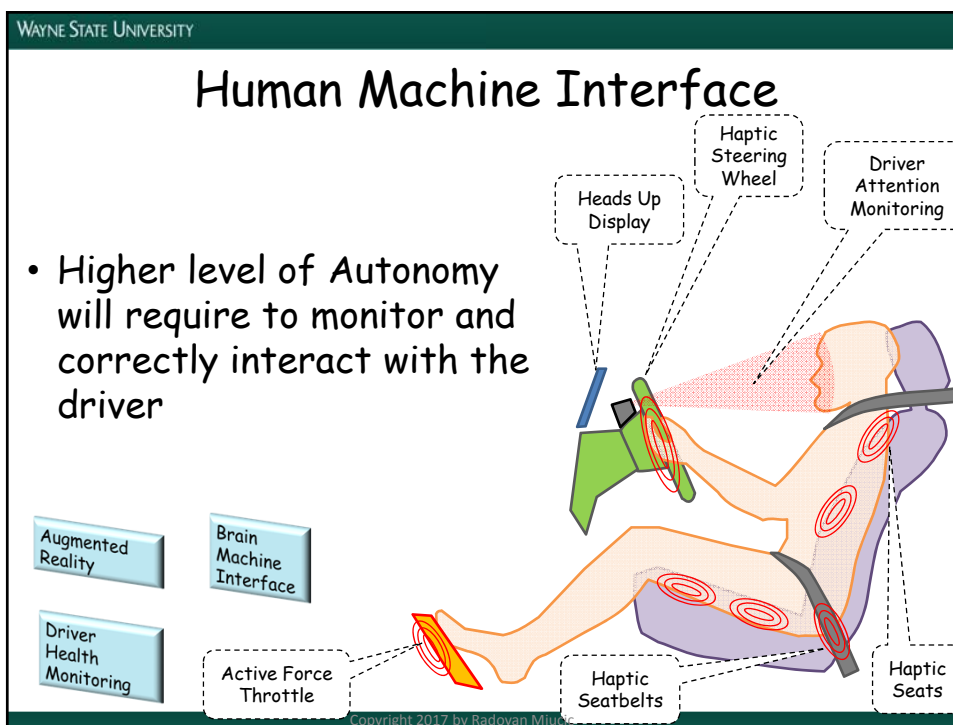
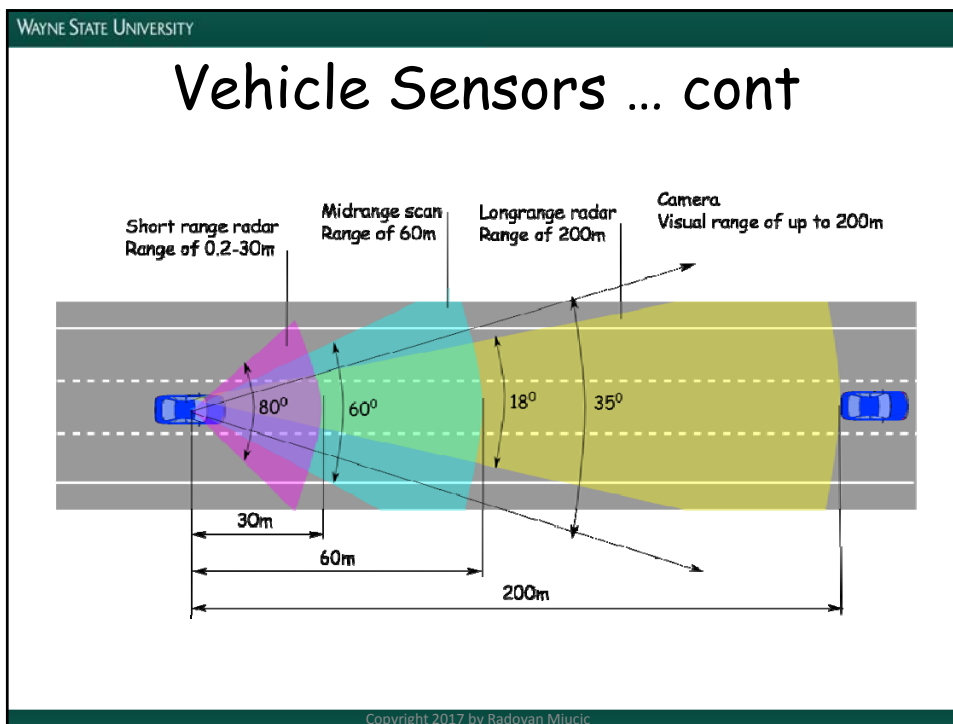

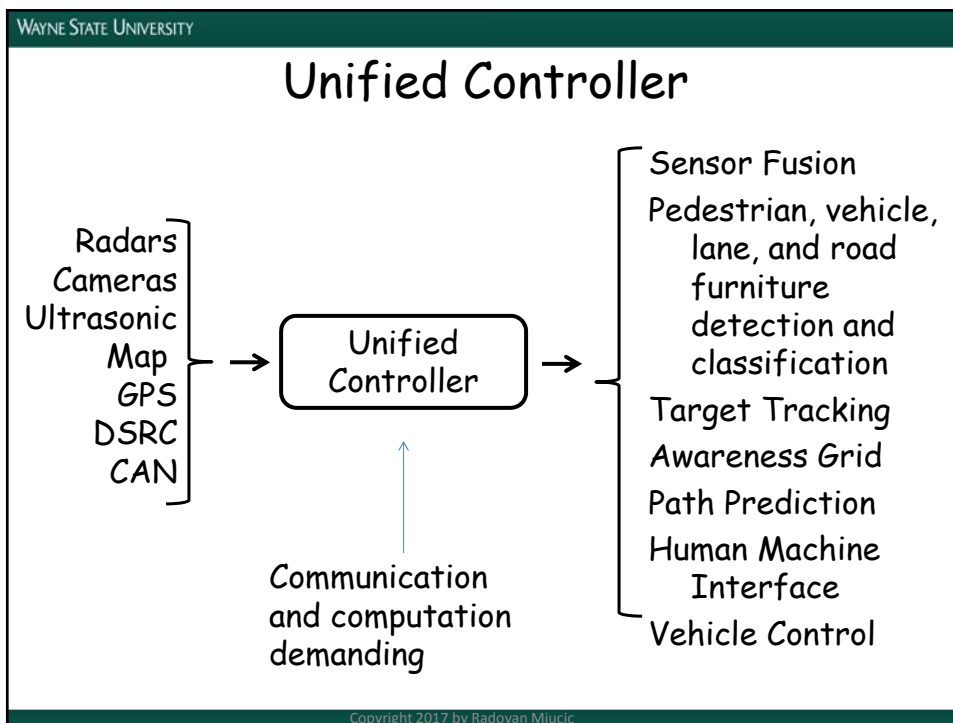
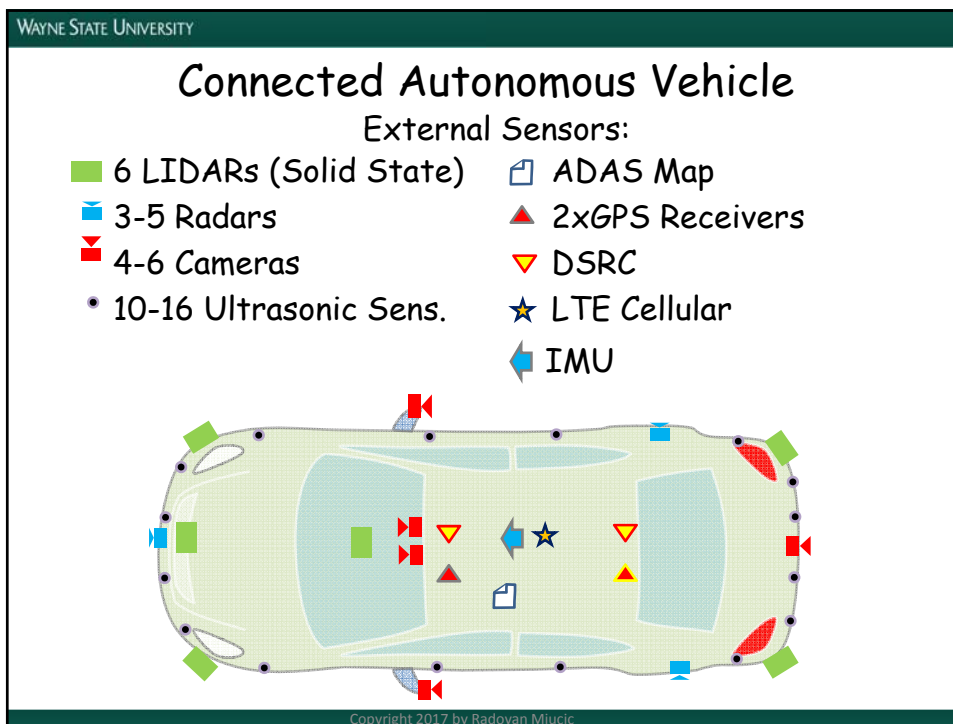

DSRC Scalability

Prepared by Radovan Miucic

DSRC Scalability

[Video](#)

DSRC Scalability

Problem Statement

Assumptions:

- All vehicle in the future are equipped with DSRC radios
- For V2V applications vehicles send out BSMs frequently (periodically)

Problem:

- How many vehicles can communicate in the same communication range?

DSRC Scalability

- From the example in lecture 8 for one BSM of 300 bytes channel is occupied for 448us ~ 0.5ms.
- Transmission frequency is 10 BSM/second
- Therefore each vehicle occupies 5ms in a 1 seconds or 0.5% of the channel
- Assuming that vehicles send BSMs one after another (not a realistic assumption in CSMA/CA) there can be at most 200 vehicles in a given communication range before BSMs start colliding over the air. In practice much less than 200 vehicles causes BSMs to collide over the air.

Transmission Parameters

- Focus on V2V msgs (most frequent)
- Transmission Parameters
 - Message rate [packets/second] or message frequency [Hz] (how many msgs a vehicle sends per second?)
 - Data rate [MBPS] - (how many bits are transmitted per second?)
 - TX power [dBm] - (how far can msg travel?)
 - Message size [bytes]

Data Rate and Msg Frequency

- In a 10 MHz channel data rate (6 MBPS) is fixed and it is optimized for multipath and high mobility vehicular environments.
- Message frequency and communication range is determined by the application needs.
 - Msg. frequency of 10 Hz suffice all V2V applications (e.g. EEBL, FCW, BSW/LCW)
 - adjusting frequency to be 2-10 Hz is considered

Message Frequency

- Lower message frequency less timely support for the V2V application.
- Higher message frequency more chances for OTA collisions and increased communication congestion.
- A vehicle traveling 80mph (36 m/s) and transmitting at 10Hz will update its position every 3.6m

Transmission Power

- Transmission power translates into the communication range and interference range.

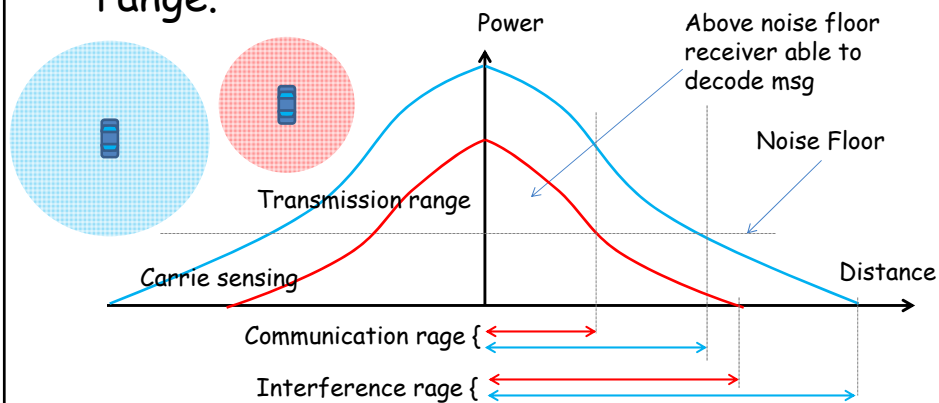

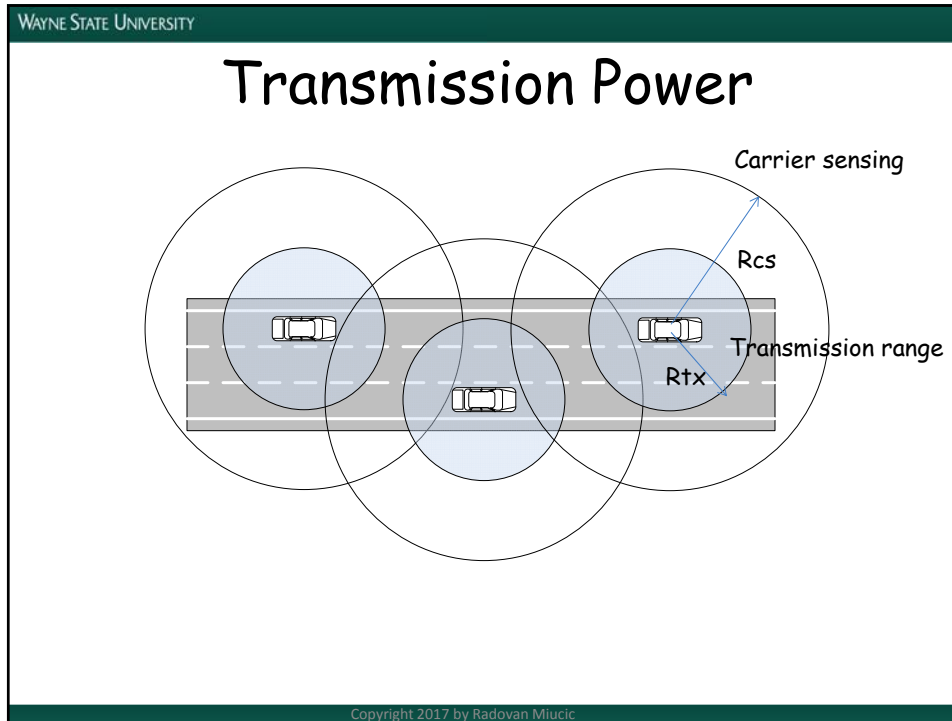

WAYNE STATE UNIVERSITY

Channel Load Assessment

- Channel load is determined with Clear Channel Assessment (CCA) function available on all IEEE 802.11 devices
- PHY layer declares channel busy when the cumulative power received within certain interval exceeds the carrier sensing threshold (CST).
- WAVE radios periodically invoke CCA to calculate fraction of the time channel is busy -> Channel Busy Ratio (CBR)

Copyright 2017 by Radovan Mucic

Communication Congestion Mitigation Strategies

- Adjust TX Power
 - Based on the feed back from the vehicles within its carrier sensing range
- Adjust message rate
 - Based on the dynamics of the host vehicle

DSRC Security, Privacy, Threats and Requirements

Prepared by Radovan Miucic

- 60 Minutes Video
<https://youtu.be/7E1WsdODxu0>
- Car Hacking DARPA
<https://youtu.be/zurrQiETDHA>

Adversaries

- Individuals or organizations that mount security and privacy attacks
- Based on the resources and capabilities, adversaries can be classified as:
 - **Individuals** operating on their own with limited \$ (computer hackers, car enthusiasts, electronics hobbyists and researchers)
 - **Loosely coordinated groups**, little more \$, e.g. and individual obtain private key from a vehicle shares it with others via internet
 - **Insiders** owning sensitive information about the security system e.g. have access to the security servers
 - **Adversary organization** abundant \$ and sophisticated technologies
 - **Foreign government:** highly organized, abundant \$ and sophisticated technologies
 - **Domestic government:** highly organized, abundant \$ and sophisticated technologies, permitted to breach driver privacy.

Security Threats

- Send false safety messages using valid security credentials
- Falsely accuse innocent vehicles
- Impersonate vehicles or network entities
- Denial of service attacks

TX False Msgs with Valid Credentials

- Send false safety messages using valid security credentials
 - Altering inputs to the OBU
 - Installing malicious SW
 - Adding devices onto the vehicle CAN that are then used to feed OBU
 - Compromising OBU SW and HW
- E.g. adversary can send counterfeited BSMs (wrong position, speed, brakes status...) to other vehicles causing them to issue false warnings.

Falsely Accuse Innocent Vehicles

- To identify misbehaving vehicles, vehicles may be required to report observed misbehavior.
- Global misbehavior detection system may use these reports from multiple vehicles to identify misbehaving vehicle.
- However, misbehaving vehicle can abuse the reporting system and falsely accuse an innocent vehicle undermining the misbehavior detection system.

Impersonate Vehicles or Network Entities

- Vehicle pose as a different vehicle using compromised credentials.
- Sybil attack: a malicious vehicle broadcasts safety messages in attempt to convince that there are more vehicles present than there actually are.

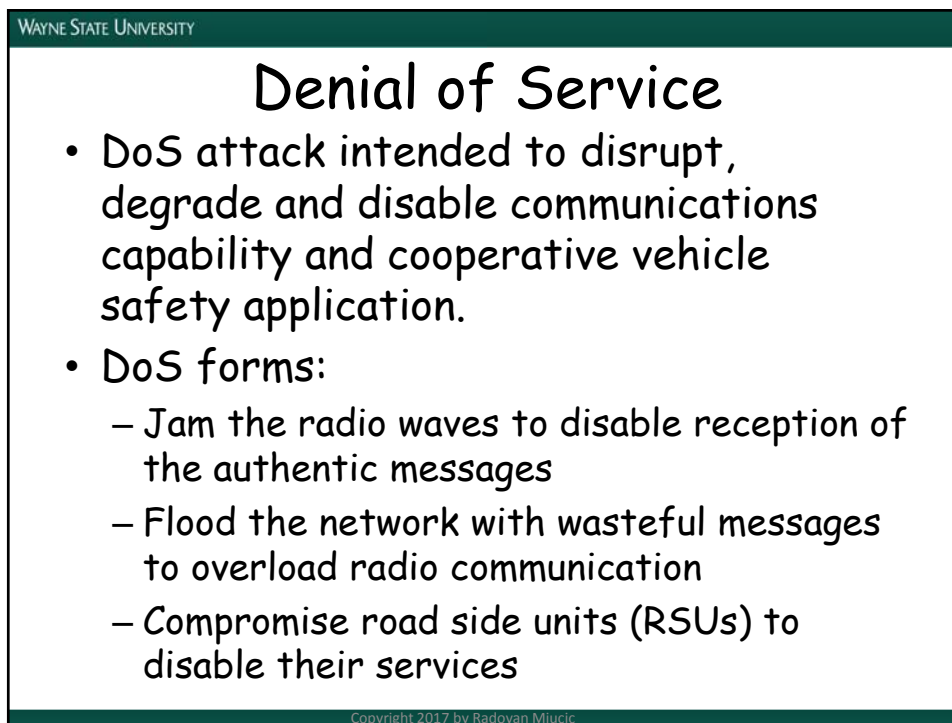
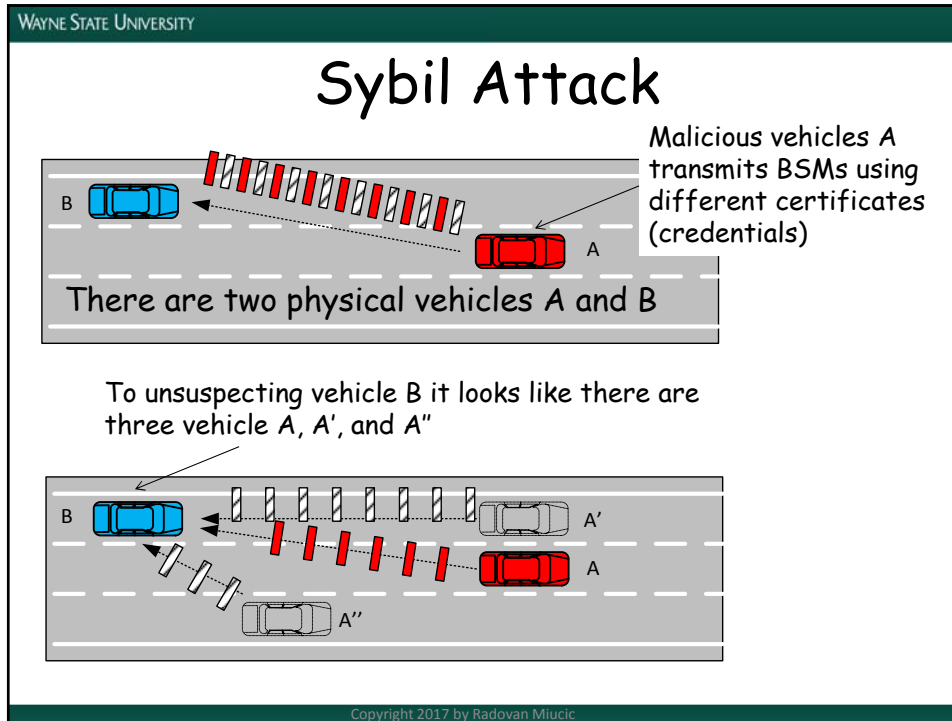

Compromise OBU SW or HW

- It has been shown that software and hardware of a modern automobile can be hacked remotely.
- Researches from University of Washington and University of California San Diego have used cellular connection to the vehicle and the function intended fro remote software upload to hack into a vehicle.
- Malicious code inserted into the OBU can be used to mount previously described attacks.

Privacy Threats

Privacy in a vehicle network:

- Vehicle anonymity
- Message linkability
 - Short term message linkability
 - Is needed for needed for proper functionality of cooperative vehicle safety applications
 - Long term message unlinkability
 - It is desired that messages cannot be linked to the sender over time span

Long Term Message Unlinkability

- If a vehicle A travels next to the RSE every day, RSE should not be able to identify vehicle A just by examining vehicle A's BSMs. The system should not allow vehicles to be tracked.

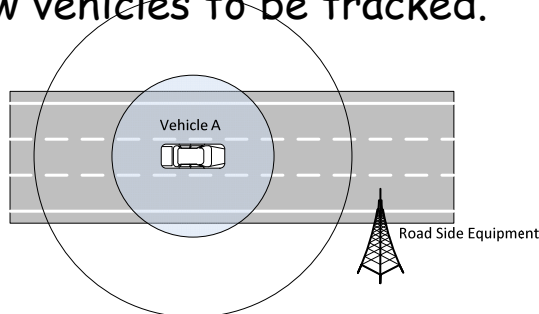

Copyright 2017 by Radovan Mlucic

Short Term Message Linkability

- E.g. vehicle A should be able to connect the messages and attribute them to vehicle B for proper VSC application (such as FCW or EEBL)

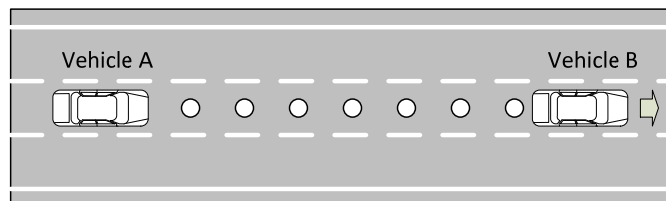

Copyright 2017 by Radovan Mlucic

Basic Security Capabilities

- Authentication
- Misbehavior Detection and Revocation
- Data Integrity

Authentication

- Broadcast msg authentication: the ability for vehicles to determine whether a broadcast msg is from a another vehicle or RSU authorized to send such a msg
- Vehicles and RSU must trust one another
- Trust is needed for safety applications
- It does not require uniquely identifying the message originator, it is sufficient to determine that originator is part of a group (vehicle or RSU) entitled to send given message.
- This can be achieved with use of Public Key Infrastructure (PKI)

Misbehavior Detection and Revocation

- Misbehavior Detection: ability to detect malicious entities (vehicles)
- Revocation: removing the privilege of sending messages that others will trust, effectively removing misbehaving entities from the system.
- Requirement for the real world deployment of the vehicle safety communications system

Data Integrity

- Data have not been altered in an unauthorized manner
- Data can be altered by:
 - faulty equipment(noisy signal)
 - Deliberately (maliciously)
- Vehicle should be able to have diagnostic functions during data collection to locally discover faulty (noisy) signals before composing BSMs

Privacy Protection Capabilities

- Privacy-preserving system should support:
 - Vehicle anonymity
 - Message long term unlinkability
- Linking msgs over short time period is not a security concern and usually it is required for cooperative apps.
- Long term unlinkability should be cost prohibitive for the potential adversaries.

Design and Performance

- Scalability:
 - Must be scalable to support 250 million vehicles (currently in use in the US)
 - If each vehicle uses a different certificate every 5 minutes, and it is reloaded every month, it means that system needs to support over 2 trillion certificates in operation.
- Currently the largest digital certificate provider (VeriSign) supports only tens of millions of certificates in operation today (mostly for Internet)

Balancing Competing Requirements

- Supporting Security
 - Should not impact Enabling Vehicle Safety Apps
 - Important to support message long term unlinkability, many apps require short term linkability.
 - Should not jeopardize driver privacy
- Protecting Privacy
 - Not jeopardize ability to detect misbehaving vehicles (when vehicles are anonimus and msgs are unlinkable it is difficult to do misbehavior detection)
- Enabling Cooperative Vehicle Safety Applications



Minimal Side Effects

- Security and Privacy Protection should not:
 - Cause excessive disruption to the driving public (cause drivers to bring vehicles to dealers)
 - Create excessive computational burden and wireless overhead
 - Open new risks that can result from abusing privacy protecting system by adversaries

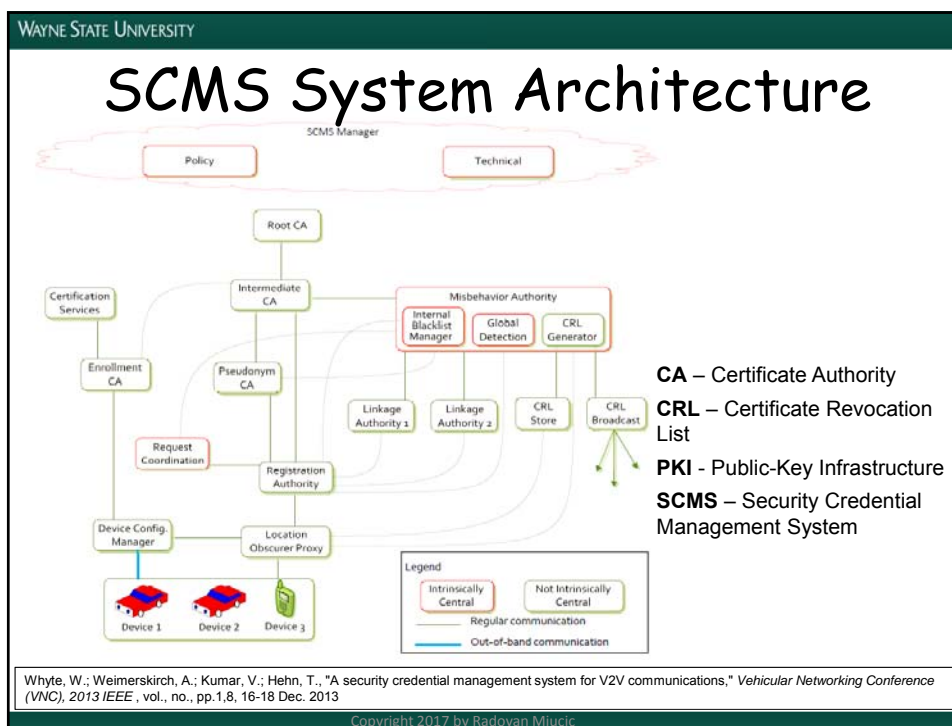

WAYNE STATE UNIVERSITY

Question

Contact:
Radovan Miucic
radovan@wayne.edu

Copyright 2017 by Radovan Miucic