



AMTEC Modules

AMT 100: Computer Literacy

AMT 1001: Orientation to Computer Systems
AMT 1002: Operating Systems
AMT 1003: Computer Applications
AMT 1004: Internet/Intranet

AMT 101: Fluid Power and Electrohydraulics/Pneumatics

AMT 1011: Fundamentals of Fluid Power & Electrohydraulics/Pneumatics
AMT 1012: Flow, Directional, Pressure Control Valves
AMT 1013: Pumps, Actuators, & Accumulators
AMT 1014: Reservoirs, Fluids, & Filters
AMT 1015: Hose, Piping, & Tubing
AMT 1016: Electrohydraulics/Pneumatics
AMT 1017: Systems and System Troubleshooting

AMT 102: General PM and Predictive Maintenance

AMT 1021: Basic PM
AMT 1022: Advanced Technologies

AMT 103s: PLC (Siemens)

AMT 1031s: Introduction to Siemens PLC's
AMT 1032s: Siemens Hardware and Software (I/O)
AMT 1033s: Programming Siemens PLC's
AMT 1034s: Siemens PLC Communication

AMT 103ab: PLC (Allen-Bradley/Rockwell)

AMT 1031ab: Introduction to Allen-Bradley PLC's
AMT 1032ab: Allen-Bradley Hardware & Software
AMT 1033ab: Programming Allen-Bradley PLC's
AMT 1034ab: Allen-Bradley PLC Communication

AMT 104: Blueprint Reading/Schematics

AMT 1041: Drafting Fundamentals
AMT 1042: Orthographic Interpretation

AMT 105: Robotics

AMT 1051: Introduction to Robotics
AMT 1052: Programming/Editing
AMT 1053: Maintenance and PM
AMT 1054: Troubleshooting Using Error Codes
AMT 1055: Integration of PLC with Robotics

AMT 106: Controls & Instrumentation

AMT 1061: Fundamentals
AMT 1062: Sensors & Photoeyes
AMT 1063: Calibration and Loop Tuning
AMT 1064: Final Control Elements

AMT 107: Basic Electricity & Electronics

AMT 1071: Introduction to Basic Electricity
AMT 1072: Instruments
AMT 1073: Components & Circuits
AMT 1074: Solid State Devices

AMT 108: Mechanical Systems/Mechanical Drives/Power Transmissions

AMT 1081: Basic Mechanical Power Transmission
AMT 1082: Flexible Drives
AMT 1083: Couplings and Alignment
AMT 1084: Bearings, Shafts, & Seals
AMT 1085: Brakes & Clutches
AMT 1086: Gears & Cams

AMT 109: Safety

AMT 1091: Basic OSHA Safety
AMT 1092: Hoists & Cranes
AMT 1093: Rigging Awareness & Fundamentals
AMT 1094: First Aid, CPR, & AED

AMT 110: Welding & Fabrication

AMT 1101: Introduction to Welding
AMT 1102: SMAW
AMT 1103: GMAW
AMT 1104: Oxy/Fuel Cutting and Joining

AMT 120: Machine Tool Operations

AMT 1201: Introduction to Machining Operations
AMT 1202: Measuring & Layout Tools
AMT 1203: Hand & Power Tools
AMT 1204: Saws
AMT 1205: Drill Press
AMT 1206: Turning
AMT 1207: Milling



Student Performance Using AMTEC Modules

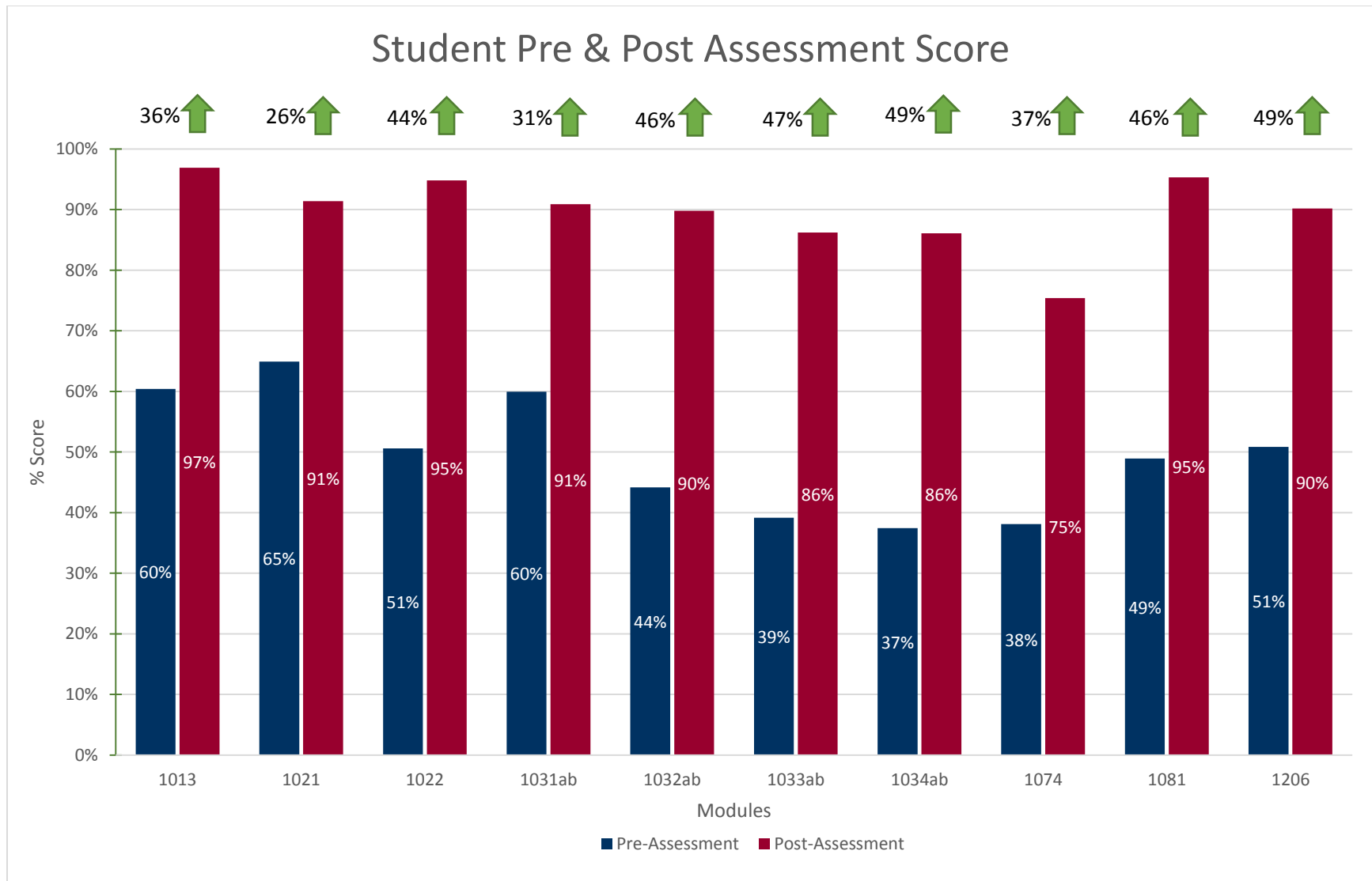

Average AMTEC Module Student Population = 20

Average of Average Percentage Change in Scores = 39%

Average Pre-Assessment Score = 52%

Average Post-Assessment Score = 92%

AMTEC Module Descriptions

AMT 100: Computer Literacy

- Introduces participants to the typical computer systems and basics of using operating systems related to advanced manufacturing industry
- Covers how to use application program software such as Microsoft Office
- Provides students with basic skills in using Internet and Intranet to search for manuals, software, drivers, etc.

AMT 101: Fluid Power and Electrohydraulics/Pneumatics

- Covers principals of fluid power, calculations of physical properties of fluids, trouble shooting fluid power components and systems with an emphasis on safety
- Explains how to use control valves, pumps, actuators, accumulators, reservoirs, fluids, filters, hose, piping, tubing, and preventive and predictive maintenance techniques

AMT 102: General PM and Predictive Maintenance

- Activities include how to check for wear and tear, replacing components to avoid breakdown, lubricating, cleaning, and testing to keep equipment optimized for efficiency and accuracy

AMT 103s: PLC (Siemens)

- Overview of Siemens PLC system architectures, networks and software options.
- Addresses industrial communications, how to start a new project, wiring and configuration, understanding the programming

AMT 103ab: PLC (Allen-Bradley)

- Overview of Allen-Bradley PLCs system architectures, basic numbering systems, computer terminology, industrial communications
- Learn about wiring and configurations of I/O modules, ladder logic programming, function block programming, etc.

AMT 104: Blueprint Reading/Schematics

- Read, manipulate, and understand a mechanical part print
- Recognize, identify, describe, and relate the components used in schematics and symbols

AMT 105: Robotics

- Introduces basic components, types of robots, safety, programming, and integrating PLC with robot applications
- Covers robot maintenance, preventative maintenance, and troubleshooting robots using error codes



AMTEC

Ignite. Educate. Accelerate.

AMT 106: Controls & Instrumentations

- Teaches how to troubleshoot/replace/install circuit boards, sensors, and photoeyes
- Shows how loop tuning will assure quality standards, what different modes of control have on maintaining process quality
- Become proficient in troubleshooting motors and variable speed drives, interpreting relay logic, interpreting relay logic and sizing of components for various applications

AMT 107: Basic Electricity & Electronics

- Introduces various elements of basic electricity such as the identification of electrical symbols as well as interpretation of schematics, cross referencing prints, tracing circuits, interpreting charts
- Explains different electrical measurement instruments with safe measuring techniques emphasized. Various circuits as well as combinational and sequential ladder logic designs are examined.

AMT 108: Mechanical Systems/Mechanical Drives/Power Transmissions

- A mechanical system consists of a combination of components that function together to perform work and motion. Mechanical drive systems may also change the size, direction, and speed of the applied force
- Covers power transmission, calculation of speed and force, mechanical drawing, safe work practices, common hand tools
- Learn about flexible chain drives, how to install, align, and maintain shaft couplings
- Introduces the various components of the mechanical systems such as bearing, shafts, seals, brakes, clutches, gears, and cams

AMT 109: Safety

- OSHA regulations, safety rules related to the use of cranes, hoists, and rigging equipment
- American Red Cross First Aid/CPR/AED program is available for additional fee

AMT 110: Welding & Fabrication

- Covers shielded metal arc welding, gas metal arc welding, oxy-fuel welding cutting
- Various techniques, equipment, filler metals, and safety

AMT 120: Machine Tool Operations

- Emphasis on safe applications of machining procedures and machines used by multi-skilled industrial maintenance technicians
- Measuring and Layout Tools, Hand and Power Tools, Saws, Drill Press, Lathes, Milling
- Various types of each tool are explored

AMTEC Assessments

AMTEC is a leading certifying organization for the nation's multi-skilled maintenance in advanced manufacturing. The comprehensive assessment system are high stakes for students and workers and provides a pipeline of individuals with the core competencies of multi-skilled maintenance. A rigorous development process was used to ensure that the assessments conform to the highest accreditation standard.

General Maintenance – Mechatronics Certification Test

The AMTEC Certification in General Maintenance—Mechatronics recognizes individuals who demonstrate mastery of the core competencies in multi-skilled maintenance. The certification test is based on AMTEC's industry-certified, nationally validated skill standards. The assessment is delivered online through Nocti Business Solutions and contains 186 multiple-choice questions and provides sub scores in 19 major content areas. The certification test can be used to document competencies of potential and current workers in the multi-skilled content.

Diagnostic Assessments

AMTEC also provides 12 standardized diagnostic assessments (multiple choice format) aligned to the industry standards as allocated into 12 major content areas. These assessments were developed and validated by industry experts and can be used to diagnose the training needs of students and incumbent workers. The results of these assessment align directly to the award-winning instructional modules for targeted remediation. These diagnostic assessments are available through Nocti Business Solutions.

- | | |
|--|---|
| 1. Fluid Power & Electrohydraulic/Pneumatics | 8. Basic Electricity and Electronics |
| 2. General PM and Predictive Maintenance | 9. Mechanical Systems/Mechanical Drives/Power Transmissions |
| 3. PLC [Allen Bradley/Rockwell] | 10. Safety |
| 4. PLC [Siemens] Under Development | 11. Computer Literacy |
| 5. Blueprint Reading/Schematics | 12. Welding and Fabrication |
| 6. Robotics – FANUC | 13. Machine Tool Operation |
| 7. Controls & Instrumentation | |

The AMTEC Mechatronics Curriculum, Assessments, and Equipment are all industry led and validated. Subject matter experts from multiple companies in various locations assisted in the creation of all AMTEC materials. These subject matter experts are from the front line workforce that complete the day to day operations which ensures that the skills learned by our students will be skills they will need and use in their career. Our materials cover all credits needed for an Associate's Degree, except general education courses. To learn more about the assessment development process or any other information regarding AMTEC, please visit autoworkforce.org.

AMTEC Manufacturing System Simulator

The AMTEC Manufacturing System Simulator was designed and built with flexibility and variety in mind by AMTEC Industry Partners. This equipment was developed as a platform for troubleshooting and safety training as well as reinforcing basic principles learned in a classroom environment. The Simulator was specifically designed to support AMTEC curriculum and can support Allen Bradley Programmable Logic Controls and Siemens Programmable Logic Controls.

The Simulator will support technical training at a variety of institutions including schools and manufacturing facilities. It is a viable platform for “Lean Manufacturing” training and is adaptable to local needs and transportable. Relevant training is easily matched to the Simulator.

FANUC America Corporation is the official retailer for the AMTEC Manufacturing Simulator. This exclusive package to all AMTEC education partner locations provides:

- The complete AMTEC Integrated manufacturing Simulator (IMS) trainer with FANUC LR Mate Robot and R30i Controller
- Partner schools will be supplied with 25-50 FANUC ROBOGUIDE Simulation Software licenses and ROBOGUIDE eLearn training at no additional cost
- FANUC (an IACET provider) will certify the instructor in FANUC Handling Tool Operations and Programming and in-turn, the instructor can provide students the same industry recognized FANUC endorsed certification
- Instructor will receive CEU credits for their FANUC training and certification
- Partner schools will have local service and sales support provided by FANUC and/or FANUC’s Education Authorized Reseller



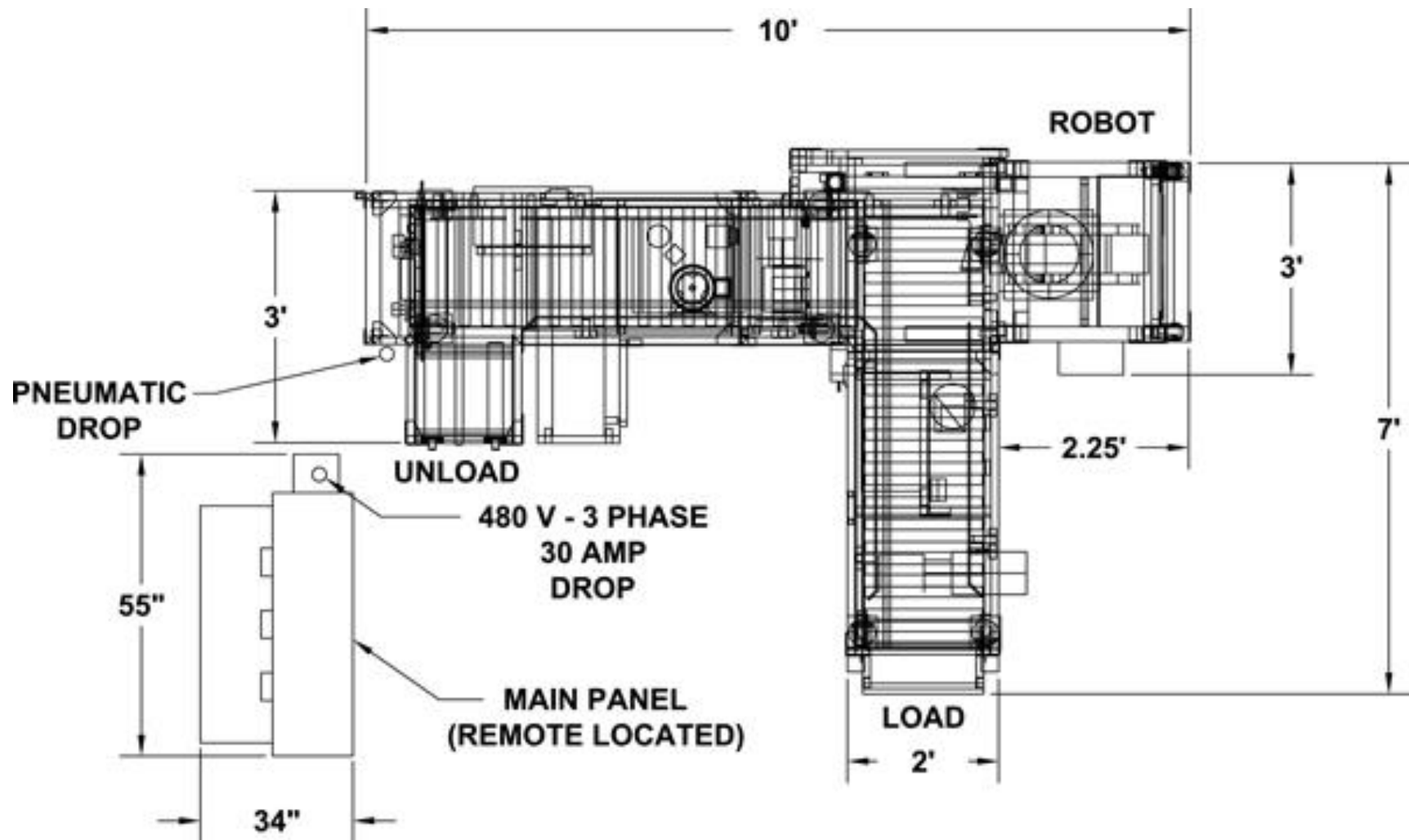

To order an AMTEC Integrated Manufacturing Simulator please email amtec@kctcs.edu or call **859-256-3100** and request to speak with an AMTEC representative. Please visit autoworkforce.org to learn more about AMTEC!