



Tolerances in Engineering Drawings

When looking at engineering drawings of a guitar or guitar components, the size and location of all the features of a design will be shown using dimensions. The dimensions tell us the theoretically perfect size or location using a single number. However, nothing can be made perfectly since variations in material and processes create slight imperfections no matter how hard we try. Even when we can create something almost perfectly, it is often too time consuming or expensive to do it on a mass production scale. That's why we must specify tolerances on drawings. Tolerances are the allowable amount of variation in a size or location of a dimension. The amount of imperfection that is acceptable without compromising the performance of a design must be specified for each dimension value. When creating an assembly of multiple parts, all the parts must fit even though they are not a "perfect" size. Engineers and designers must tell those that are manufacturing the parts what the acceptable deviation is from the specified or theoretically perfect size. Sometimes the same tolerance may be applied to all dimensions and sometimes the tolerance is specified next to each dimension. In this lesson, you will learn to identify tolerances on a drawing, calculate the acceptable dimension of a feature, and specify tolerances for dimensions using industry standards.

Learning Objectives:

1. Students will identify the various ways that tolerances are specified on a technical drawing.
2. Students will calculate the minimum and maximum size of a part or location based on the specified tolerance.
3. Students will specify dimensional tolerances based using available engineering information.



Standards:

CCSS.MATH.CONTENT.HSN.Q.A.2

Define appropriate quantities for the purpose of descriptive modeling.

CCSS.MATH.CONTENT.HSN.Q.A.3

Choose a level of accuracy appropriate to limitations on measurement when reporting quantities.

Materials Required:

1. Basic calculator, pencil, paper

Safety:

N/A

References:

Engineering Tolerance Defined: http://en.wikipedia.org/wiki/Engineering_tolerance
<https://www.asme.org/products/codes-standards/y145-2009-dimensioning-and-tolerancing>

Engineering Drawing Defined: http://en.wikipedia.org/wiki/Engineering_drawing
Technical Drawing with Engineering Graphics (14th Edition), Giesecke et al, ISBN: 978-0135090497





Activity:

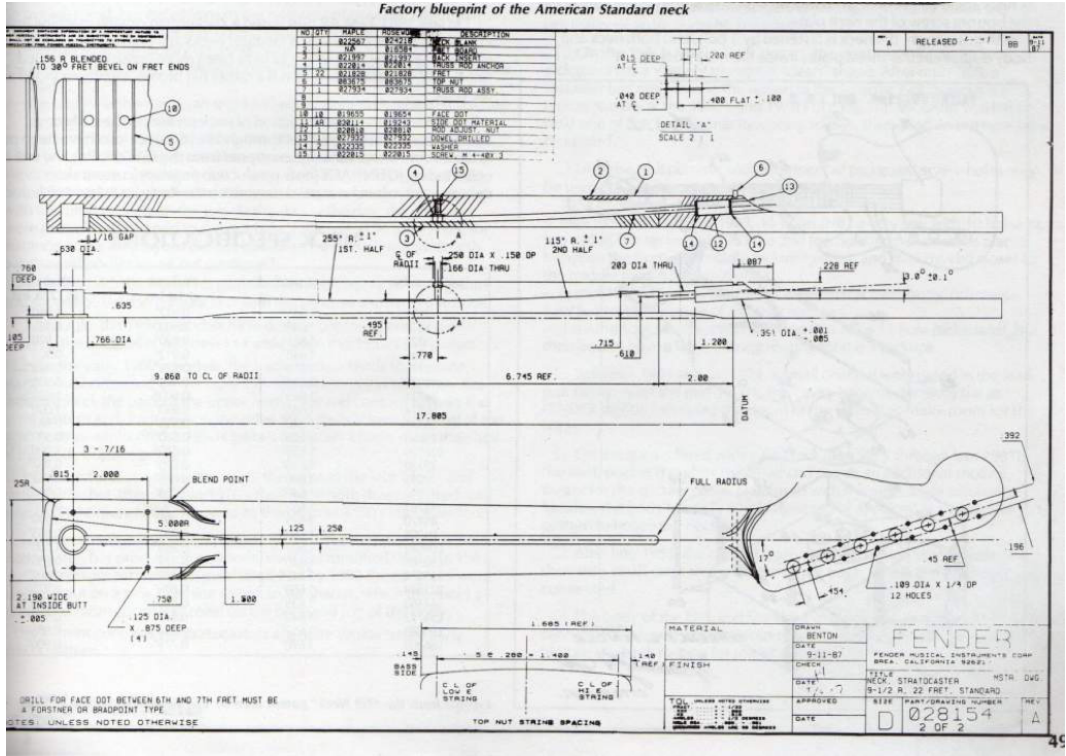

This activity will use a guitar neck plate as an example:





Consider the following engineering drawing of a neck plate:

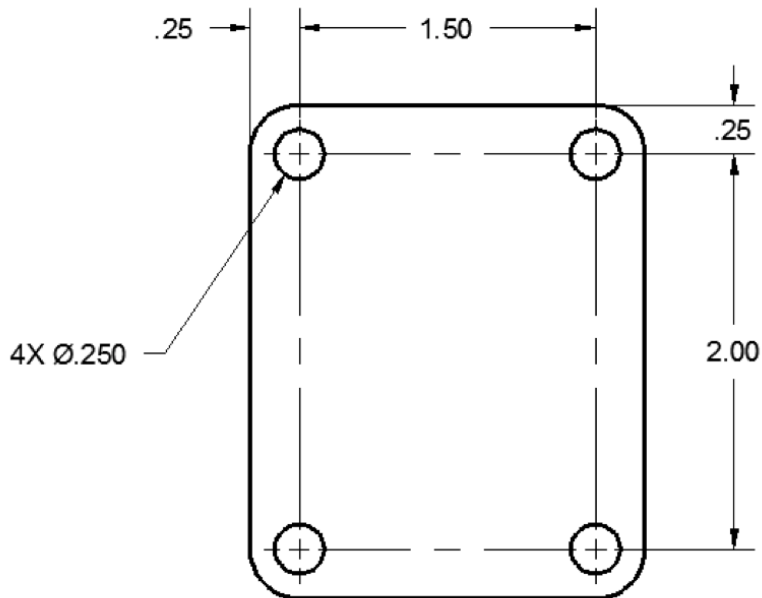

NOTES: UNLESS OTHERWISE SPECIFIED
1. TOLERANCES: X.XX \pm .03
X.XXX \pm .010

Tolerances are specified on engineering drawings in a variety of ways. All of the methods will result in communicating to manufacturers the “high” and “low” LIMITS for a specified dimension. In the example above, all of the dimensions have the tolerance specified in the general note. This is a common method for specifying tolerances where they are common to most or all dimensions. This type of tolerance is called a BILATERAL tolerance because a value is added and subtracted from the specified size. However, not all of the dimensions have the same tolerance. The dimensions with 2 place decimal precision have a tolerance of \pm .03 and the 3 place decimal dimension has a tolerance of \pm .010

So for the example above, you would need to add AND subtract .03 from each of the 2 place decimal dimensions in order to determine their maximum and minimum allowable sizes. Therefore, the 2.00 dimension would have manufacturing LIMITS of 1.97 – 2.03. When the part is inspected and has a size between or including those sizes, it is deemed acceptable. If the dimension measures larger or smaller than the specified limits, it must be rejected or possibly reworked.



What are the LIMITS of size for the other dimensions? (Show the high and low limit for each)

1. 2.00 dimension: _____
2. 1.50 dimension: _____
3. .25 linear dimension: _____
4. .250 diameter dimension: _____

Now consider this engineering drawing for the same part:

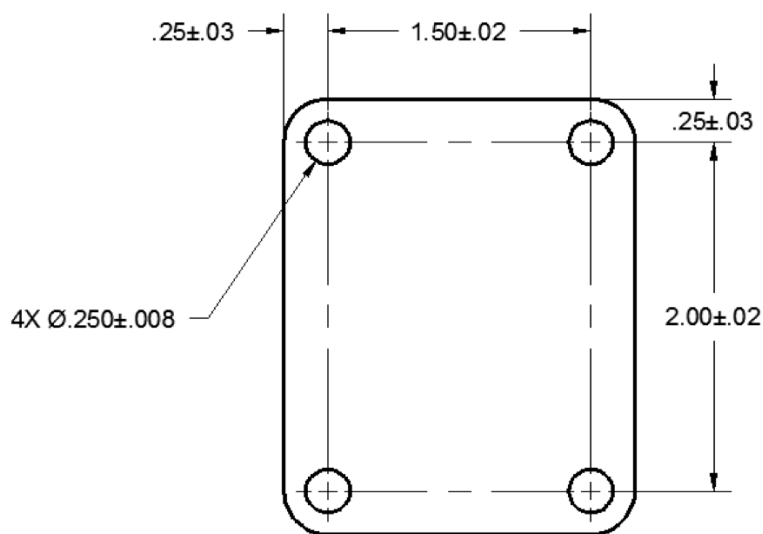

In this example, the dimensions each have their own BILATERAL tolerance assigned alongside the specified size. Note that the .250 diameter dimension has 3 decimal places of precision, as does the tolerance.

What are the LIMITS of size for each dimension?

5. 2.00 dimension: _____
6. 1.50 dimension: _____
7. .25 linear dimension: _____
8. .250 diameter dimension: _____



The TOTAL tolerance is the difference between the maximum and minimum LIMITS of a dimension tolerance or the sum of the plus and minus values. For instance, the TOTAL tolerance for the 2.00 dimensions is $(.02 + .02)$ or $.04$

What is the TOTAL tolerance for each of the dimensions?

9. 2.00 dimension: _____
10. 1.50 dimension: _____
11. .25 linear dimension: _____
12. .250 diameter dimension: _____

In the next drawing, the tolerances are also BILATERAL, but the plus value is different from the minus value. The LIMITS and the TOTAL tolerance are found in the same way as the previous example.

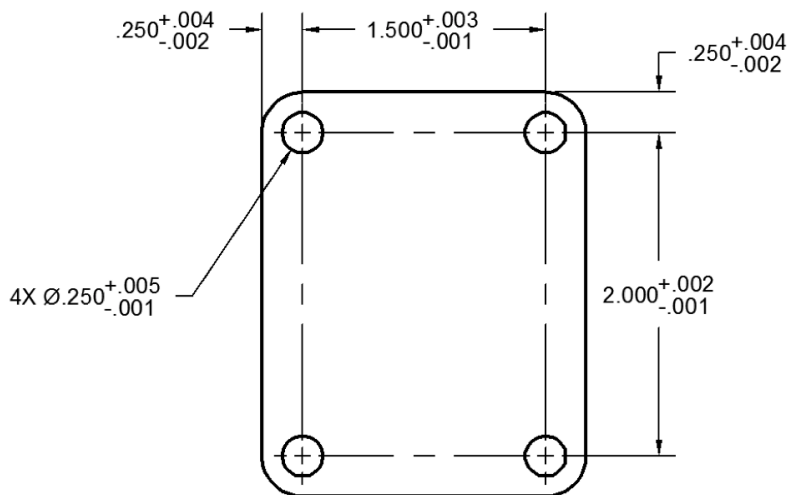

What are the LIMITS of size for each dimension?

13. 2.000 dimension: _____
14. 1.500 dimension: _____
15. .250 linear dimension: _____
16. .250 diameter dimension: _____



What is the TOTAL tolerance for each of the dimensions?

17. 2.000 dimension: _____
18. 1.500 dimension: _____
19. .250 linear dimension: _____
20. .250 diameter dimension: _____

In the next drawing, the tolerances are UNILATERAL. This means they may vary in one direction from the specified dimension; either plus OR minus. For instance, drilled holes will never be smaller than the drill bit with which they are created. They will likely be larger due to small variations in the machine tools (perhaps a little wobble of the drill bit). Therefore the tolerance will not have a minus value, but rather a plus value from the standard drill size.

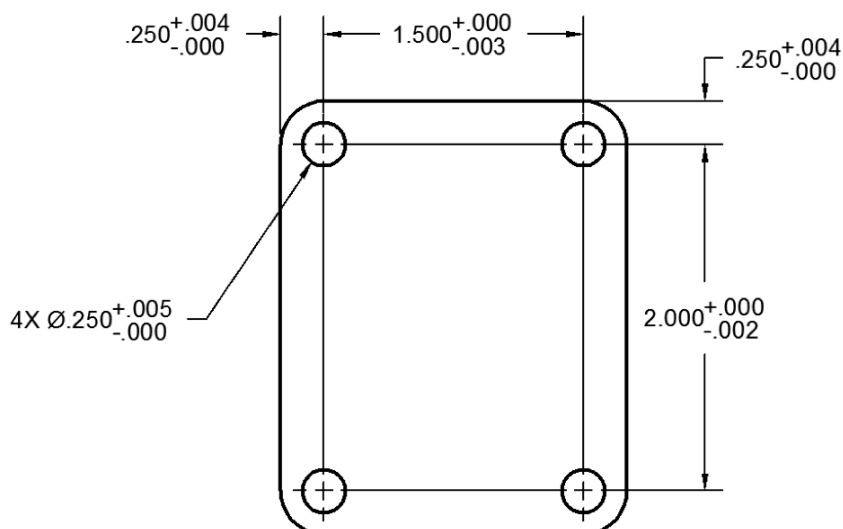

What are the LIMITS of size for each dimension?

21. 2.000 dimension: _____
22. 1.500 dimension: _____
23. .250 linear dimension: _____
24. .250 diameter dimension: _____



In this final example, the single dimension value is replaced by the tolerance shown as LIMITS.

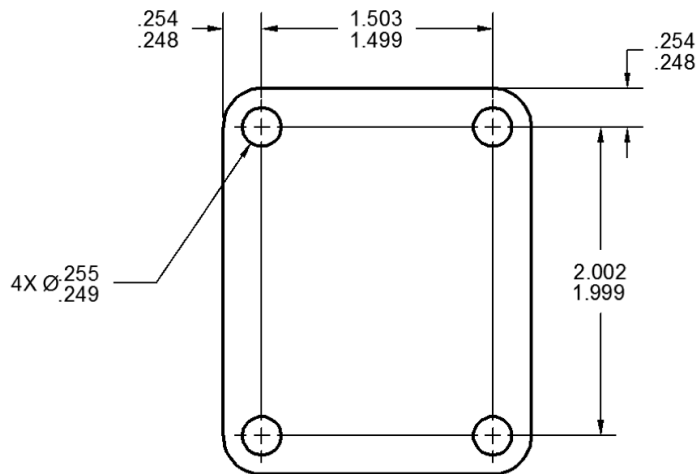

What is the TOTAL tolerance for each of the dimensions?

25. 2.002/1.999 dimension: _____
26. 1.503/1.499 dimension: _____
27. .254/.248 linear dimension: _____
28. .255/.249 diameter dimension: _____

Now it's your turn to specify some tolerances based on some given engineering information:

29. A dimension has a specified size of 3.000 and an equal BILATERAL tolerance of .005. How would this dimension appear on a drawing?

30. What is the TOTAL tolerance for this dimension?



31. A dimension has a specified size of 5.250 and can be .025 bigger or .005 smaller than the specified size. How is this dimension shown on a drawing as a BILATERAL tolerance?

32. What is the TOTAL tolerance for this dimension?

33. A dimension has a specified size of 1.000 and a positive UNILATERAL tolerance of .025. How will this dimension appear on a drawing?

34. A dimension has a specified size of 2.50 and can be .03 larger and .01 smaller than the specified size. How is this dimension shown on a drawing as a LIMIT dimension?

35. Write the general note for tolerances that would appear on a drawing with the following conditions: all 2 place decimal dimensions are $\pm .04$, all 3 place decimal dimensions are $\pm .005$, and all 4 place decimal dimensions are $\pm .0006$.



Name _____

Assessment
Tolerances in Engineering Drawings

1. Why are tolerances needed on a drawing?
 - A. To make drawings more complex.
 - B. Manufacturing processes do not result in perfect sizes or locations of part features.
 - C. To show the theoretically perfect size or location of a part feature.
 - D. To show the surface finish characteristics of a part feature.

2. What happens to a part that measures slightly larger or smaller than the specified tolerance?
 - A. The part is sent to the scrap pile
 - B. If possible, the part is reworked.
 - C. The part is shipped with the hope that nobody will notice
 - D. Answers A or B

3. What are the limits of size for a $3.00 \pm .05$ dimension?
 - A. $3.00 - 3.05$
 - B. $2.95 - 3.00$
 - C. $2.95 - 3.05$
 - D. None of the above

4. What is the total tolerance of a $5.255 \pm .005$ dimension?
 - A. .010
 - B. .005
 - C. 5.260
 - D. 5.255



5. What are the limits of size for a 5.000 dimension if the tolerance note is shown as follows:

NOTES: UNLESS OTHERWISE SPECIFIED

1. TOLERANCES: X.XX \pm .03
X.XXX \pm .010

- A. 5.000 – 5.003
- B. 4.990 – 5.030
- C. 4.970 – 5.010
- D. 4.990 – 5.010

6. Which type of tolerance is shown in the following dimension?

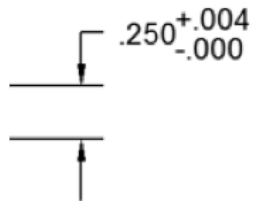

- A. Bilateral
- B. Limit
- C. Unilateral
- D. Diameter

7. What is the total tolerance of the following dimension?

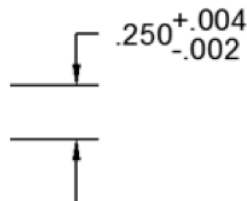

- A. .254
- B. .006
- C. .002
- D. .248



8. What is the total tolerance for the following dimension?



- A. .502
- B. .250
- C. .006
- D. .004

9. Which type of tolerance is shown in the following dimension?



- A. Bilateral
- B. Limit
- C. Unilateral
- D. Diameter

10. If using a general note to specify tolerances, which dimension would typically have the smallest tolerance?

- A. 4.0
- B. 4.12
- C. 4.005
- D. 4.1245



Assessment Key:

1. Manufacturing processes do not result in perfect sizes or locations of part features.
2. D - Answers A or B
3. C - 2.95 - 3.05
4. A - .010
5. D - 4.990 - 5.010
6. C - Unilateral
7. B - .006
8. D - .004
9. B - Limit
10. D - 4.1245

Reviewing Faculty Cohort Members:

Chad McCormack, Wells High School, Wells, ME (3/18)

Dave Parker, Noble High School, North Berwick, ME (3/18)